

■ PRODUCT CHARACTERISTICS

V_{DSS}	100V
$R_{DS(ON)}$ Typ(@ $V_{GS}=10V$)	4.3m Ω
I_D	125A

■ APPLICATIONS

- * Motor Control
- * High Performance SMPS
- * DC/DC Converter

■ FEATURE

- * Low Gate Charge
- * Ultra-low RDS(ON)

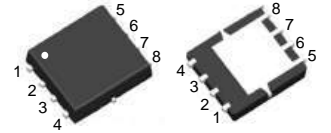
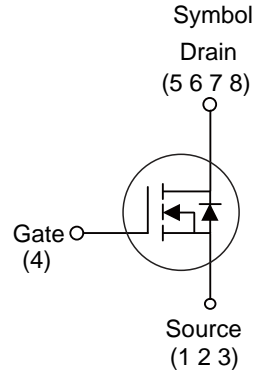

PDFN5X6

■ ORDER INFORMATION

Order Codes		Package	Packing
Halogen-Free	Halogen		
N/A	MOT1142HG	PDFN5X6	5000 pieces/Reel

■ ABSOLUTE MAXIMUM RATINGS($T_A=25^{\circ}C$, unless otherwise specified)

Parameter	Symbol	Ratings	Unit
Drain-Source Voltage	V_{DSS}	100	V
Gate-Source Voltage	V_{GSS}	± 20	V
Drain Current Continuous(@ $V_{GS}=10V, T_A=25^{\circ}C$)	I_D	125	A
Drain Current Pulsed	I_{DM}	500	A
Avalanche Energy *	E_{AS}	552	mJ
Power Dissipation	P_D	150	W
Junction Temperature	T_J	+150	$^{\circ}C$
Storage Temperature	T_{STG}	-55~ +150	$^{\circ}C$

■ THERMAL CHARACTERISTICS

Parameter	Symbol	Typ	Unit
Junction to Case	R_{thJC}	0.83	$^{\circ}C/W$

Note: * EAS condition: $T_J=25^{\circ}C, V_{DS}=30V, V_G=10V, L=0.5mH, R_g=25\Omega$

■ ELECTRICAL CHARACTERISTICS ($T_C=25^{\circ}\text{C}$, unless otherwise noted)

Parameter	Symbol	Test Conditions	Min	Typ	Max	Unit
Off characteristics						
Drain to Source Breakdown Voltage	V_{DSS}	$V_{GS}=0V, I_D=250\mu A$	100	-	-	V
Drain to Source Leakage Current	I_{DSS}	$V_{DS}=100V, V_{GS}=0V$	-	-	1	μA
Gate to Source Forward Leakage	$I_{GSS(F)}$	$V_{DS}=0V, V_{GS}=+20V$	-	-	100	nA
Gate to Source Reverse Leakage	$I_{GSS(R)}$	$V_{DS}=0V, V_{GS}=-20V$	-	-	-100	nA
On characteristics						
Drain to Source On-Resistance	$R_{DS(ON)}$	$V_{GS}=10V, I_D=20A$	-	4.3	4.9	m Ω
Gate Threshold Voltage	$V_{GS(TH)}$	$V_{DS}=V_{GS}, I_D=250\mu A$	2	3	4	V
Dynamic characteristics						
Gate capacitance	R_g	$V_{GS}=0V, V_{DS}=0V, f=1.0\text{MHz}$	-	1.3	-	Ω
Forward Transconductance	g_{fs}	$V_{DS}=10V, I_D=3A$	-	12	-	S
Input Capacitance	C_{iss}	$V_{DS}=20V, V_{GS}=0V$ $f=1.0\text{MHz}$	-	4600	-	pF
Output Capacitance	C_{oss}		-	1700	-	pF
Reverse Transfer Capacitance	C_{rss}		-	197	-	pF
Resistive Switching Characteristics						
Turn-on Delay Time	$t_{d(ON)}$	$I_D=20A, V_{DS}=50V$ $R_G=3\Omega, V_{GS}=10V$	-	21	-	ns
Rise Time	t_r		-	13	-	ns
Turn-off Delay Time	$t_{d(OFF)}$		-	40	-	ns
Fall Time	t_f		-	12	-	ns
Total Gate Charge	Q_g	$I_D=20A, V_{DS}=50V$ $V_{GS}=10V$	-	93	-	nC
Gate to Source Charge	Q_{gs}		-	21	-	nC
Gate to Drain("Miller") Charge	Q_{gd}		-	27	-	nC
Source-Drain Diode Characteristics						
Continuous Source Current(Body Diode)	I_S		-	-	125	A
Maximum Pulsed Current(Body Diode)	I_{SM}		-	-	500	A
Diode Forward Voltage	V_{SD}	$I_{SD}=3A, V_{GS}=0V$	-	0.75	1.2	V
Reverse Recovery Time	t_{rr}	$I_{SD}=20A, T_J=25^{\circ}\text{C}$	-	68	-	ns
Reverse Recovery Charge	Q_{rr}	$dl/dt=100A/\mu s$	-	115	-	nC

■ TYPICAL CHARACTERISTICS

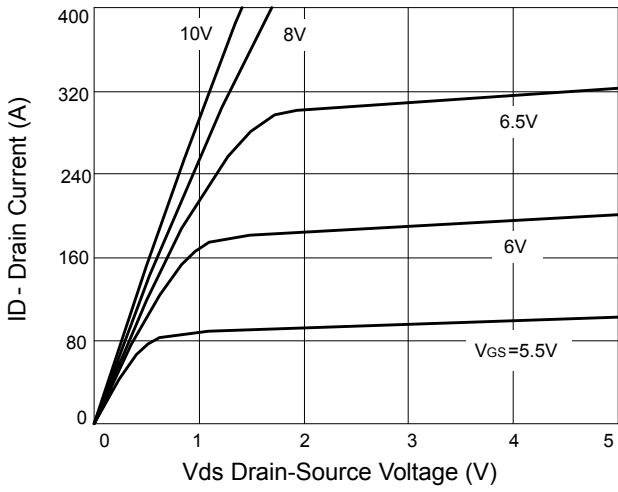

Figure 1 Output characteristics

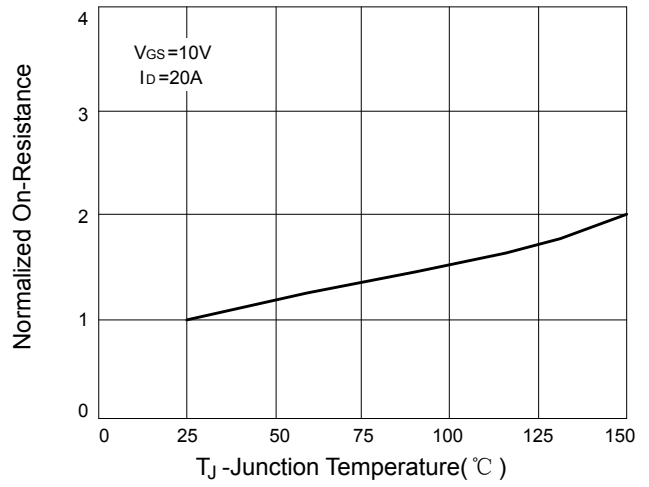

Figure 2 Rds(on)-junction temperature

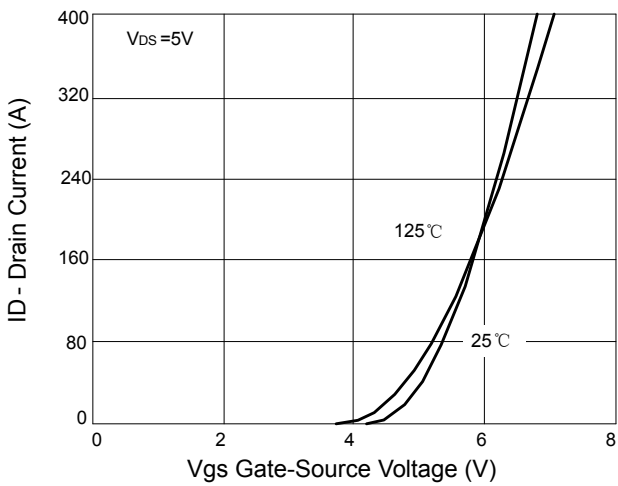

Figure 3 Transfer characteristics

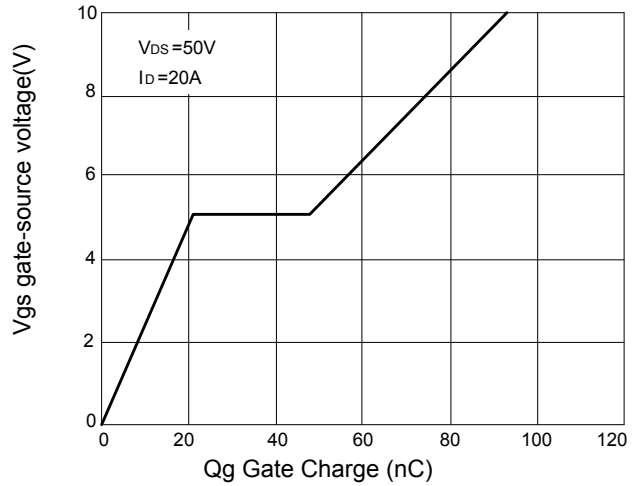

Figure 4 Gate charge

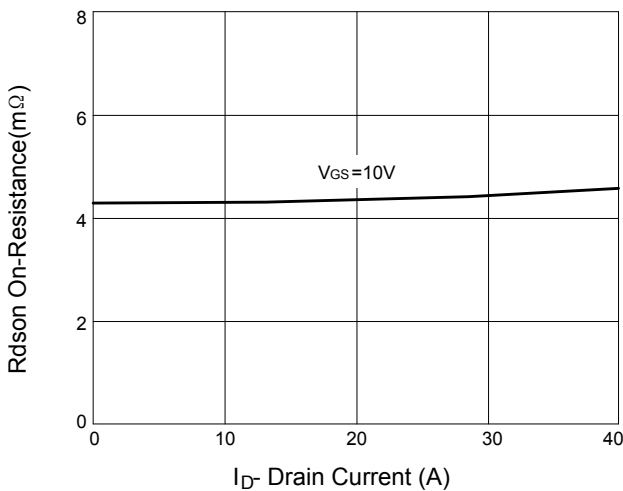

Figure 5 Rdson-drain current

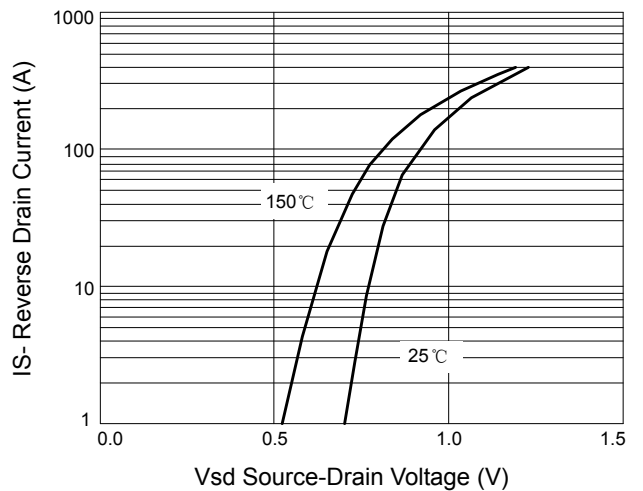

Figure 6 Source-drain diode forward

■ TYPICAL CHARACTERISTICS(Cont.)

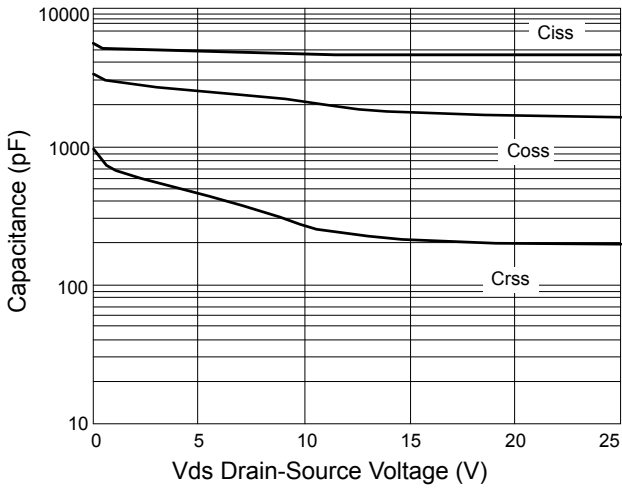

Figure 7 Capacitance vs. vds

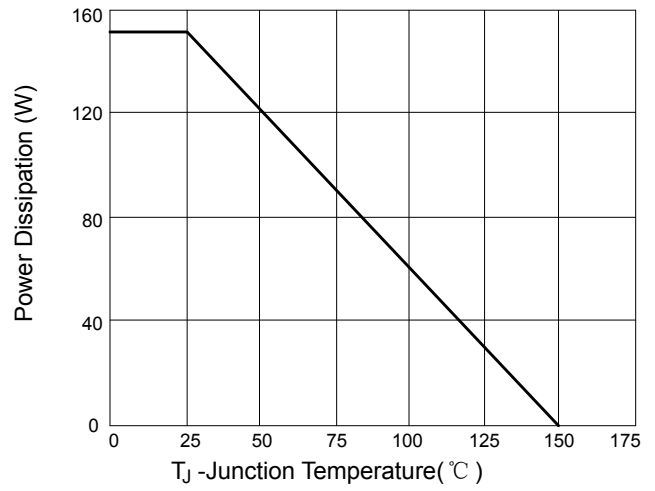

Figure 8 Power de-rating

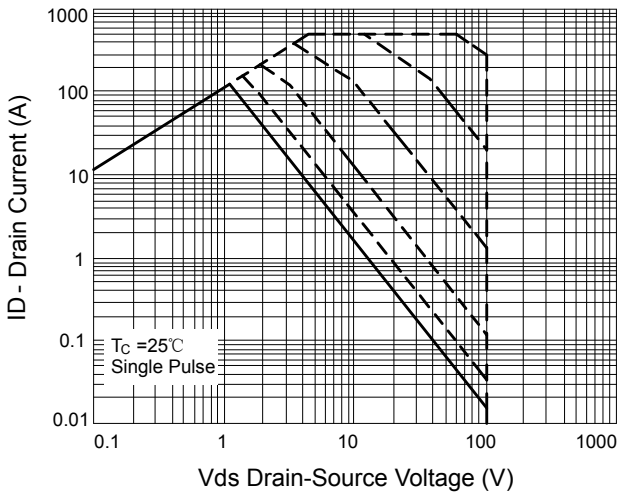

Figure 9 Safe operation area

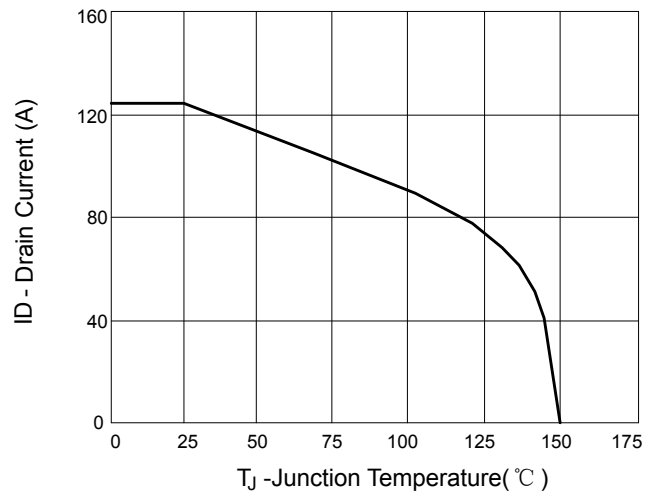
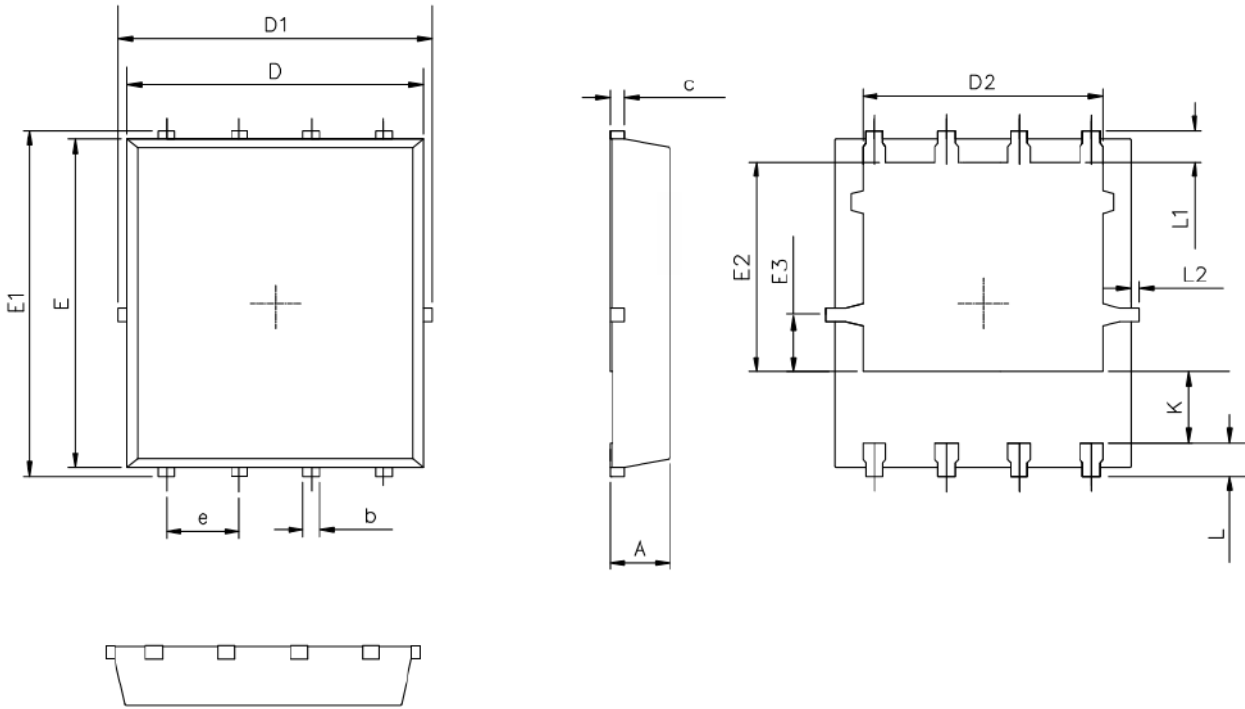
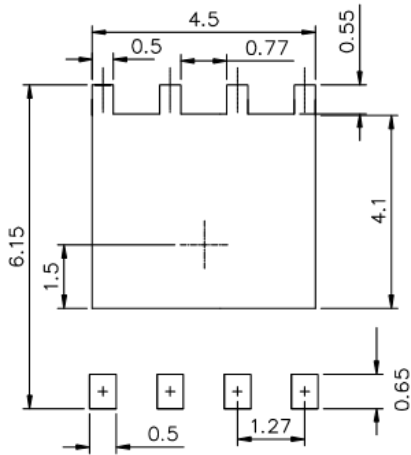

Figure 10 Current de-rating

■ PDFN5X6 PACKAGE OUTLINE DIMENSIONS



RECOMMENDED LAND PATTERN



UNIT:mm

	MIN	NOM	MAX
A	0.90	1.00	1.10
b	0.25	0.35	0.50
c	0.10	0.20	0.30
D	4.80	5.00	5.30
D1	4.90	5.10	5.50
D2	3.92	4.02	4.20
E	5.65	5.75	5.85
E1	5.90	6.05	6.20
E2	3.325	3.525	3.775
E3	0.80	0.90	1.00
e		1.27	
L	0.40	0.55	0.70
L1		0.65	
L2	0.00		0.15
K	1.00	1.30	1.50