

■ PRODUCT CHARACTERISTICS

V_{DSS}	100V
$R_{DS(ON) Typ} (@V_{GS}=10V)$	11.6m Ω
$R_{DS(ON) Typ} (@V_{GS}=4.5V)$	16.5m Ω
I_D	38A

■ APPLICATIONS

- * Electronic lamp ballasts based on half bridge
- * Load Switching, Quick/Wireless Charge.
- * Motor Driving

■ FEATURE

- * Low Gate Charge
- * Pb-Free Lead Plating

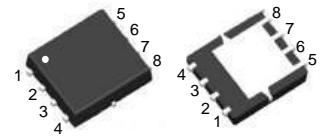
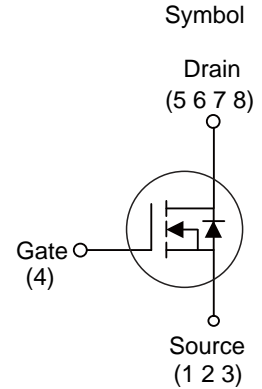

PDFN5X6

■ ORDER INFORMATION

Order Codes		Package	Packing
Halogen-Free	Halogen		
N/A	MOT1514G	PDFN5X6	5000 pieces/Reel

■ ABSOLUTE MAXIMUM RATINGS ($T_A=25^{\circ}C$, unless otherwise specified)

Parameter	Symbol	Ratings	Unit
Drain-Source Voltage	V_{DSS}	100	V
Gate-Source Voltage	V_{GSS}	± 20	V
Drain Current Continuous (@ $V_{GS}=10V, T_A=25^{\circ}C$)	I_D	38	A
Drain Current Continuous (@ $V_{GS}=10V, T_A=100^{\circ}C$)	I_D	24	A
Drain Current Pulsed	I_{DM}	152	A
Avalanche Energy *	E_{AS}	45	mJ
Power Dissipation	P_D	32	W
Junction Temperature	T_J	+150	$^{\circ}C$
Storage Temperature	T_{STG}	-55~ +150	$^{\circ}C$

■ THERMAL CHARACTERISTICS

Parameter	Symbol	Typ	Unit
Junction to Case	R_{thJC}	3.9	$^{\circ}C/W$

Note: * EAS condition: $T_J=25^{\circ}C, V_{DD}=40V, V_G=10V, L=0.5mH, R_g=25\Omega$

■ ELECTRICAL CHARACTERISTICS ($T_C=25^{\circ}\text{C}$, unless otherwise noted)

Parameter	Symbol	Test Conditions	Min	Typ	Max	Unit
Off characteristics						
Drain to Source Breakdown Voltage	V_{DSS}	$V_{GS}=0V, I_D=250\mu A$	100	-	-	V
Drain to Source Leakage Current	I_{DSS}	$V_{DS}=100V, V_{GS}=0V$	-	-	1	μA
Gate to Source Forward Leakage	$I_{GSS(F)}$	$V_{GS}=+20V, V_{DS}=0V$	-	-	100	nA
Gate to Source Reverse Leakage	$I_{GSS(R)}$	$V_{GS}=-20V, V_{DS}=0V$	-	-	-100	nA
On characteristics						
Drain to Source On-Resistance	$R_{DS(ON)}$	$V_{GS}=10V, I_D=20A$	-	11.6	16	$m\Omega$
		$V_{GS}=4.5V, I_D=15A$	-	16.5	22	$m\Omega$
Gate Threshold Voltage	$V_{GS(TH)}$	$V_{DS}=V_{GS}, I_D=250\mu A$	1	2	3	V
Dynamic characteristics						
Gate Resistance	R_g	$V_{GS}=0V, V_{DS}=0V, f=1.0MHz$	-	1.1	-	Ω
Forward Transconductance	g_{fs}	$V_{DS}=5V, I_D=5A$	10	-	-	S
Input Capacitance	C_{iss}	$V_{DS}=20V, V_{GS}=0V$ $f=1.0MHz$	-	1435	-	pF
Output Capacitance	C_{oss}		-	545	-	pF
Reverse Transfer Capacitance	C_{rss}		-	48	-	pF
Resistive Switching Characteristics						
Turn-on Delay Time	$t_{d(ON)}$	$V_{GS}=10V, V_{DS}=50V,$ $I_D=20A, R_G=6\Omega$	-	7.5	-	ns
Rise Time	t_r		-	15.8	-	ns
Turn-off Delay Time	$t_{d(OFF)}$		-	31	-	ns
Fall Time	t_f		-	28	-	ns
Total Gate Charge	Q_g	$I_D=20A, V_{DS}=50V$ $V_{GS}=10V$	-	26	-	nC
Gate to Source Charge	Q_{gs}		-	4.3	-	nC
Gate to Drain("Miller") Charge	Q_{gd}		-	6.8	-	nC
Source-Drain Diode Characteristics						
Continuous Source Current(Body Diode)	I_S		-	-	38	A
Maximum Pulsed Current(Body Diode)	I_{SM}		-	-	152	A
Diode Forward Voltage	V_{SD}	$I_{SD}=1A, V_{GS}=0V$	-	0.74	1.2	V
Reverse Recovery Time	t_{rr}	$I_{SD}=20A, T_J=25^{\circ}\text{C}$ $di/dt=100A/\mu s$	-	43	-	ns
Reverse Recovery Charge	Q_{rr}		-	35	-	nC

■ TYPICAL CHARACTERISTICS

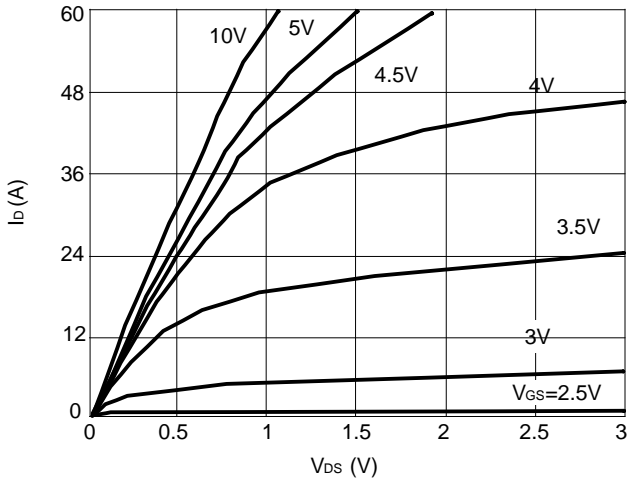

Figure 1: Output Characteristics

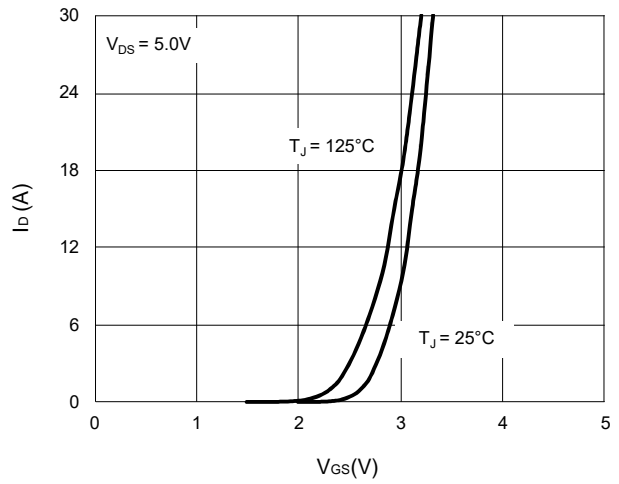

Figure 2: Transfer Characteristics

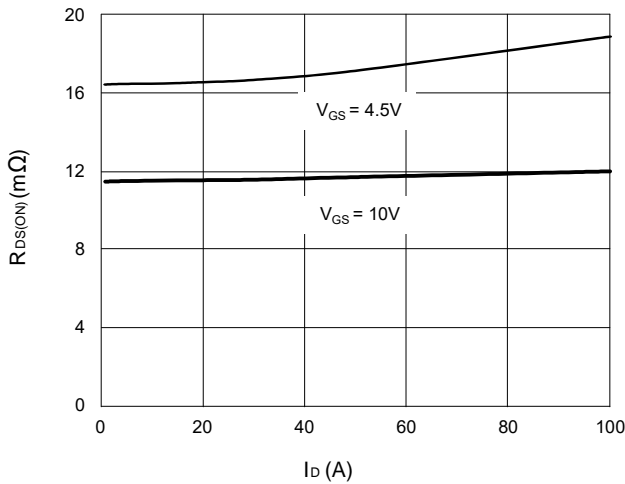

Figure 3: $R_{DS(ON)}$ vs. Drain Current

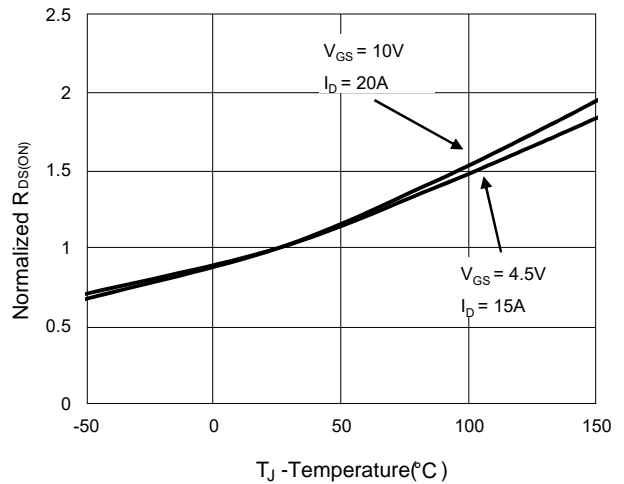

Figure 4: $R_{DS(ON)}$ vs. Junction Temperature

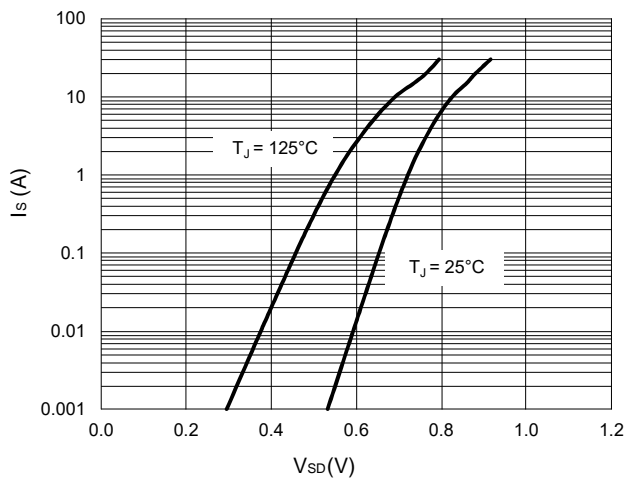

Figure 5: Body-Diode Characteristics

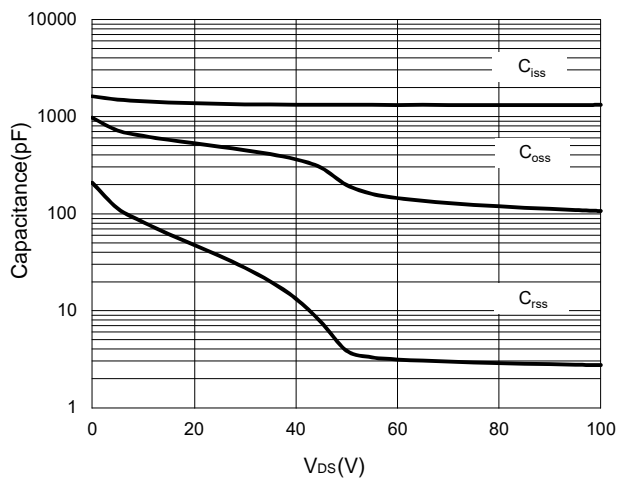

Figure 6: Capacitance Characteristics

■ TYPICAL CHARACTERISTICS(Cont.)

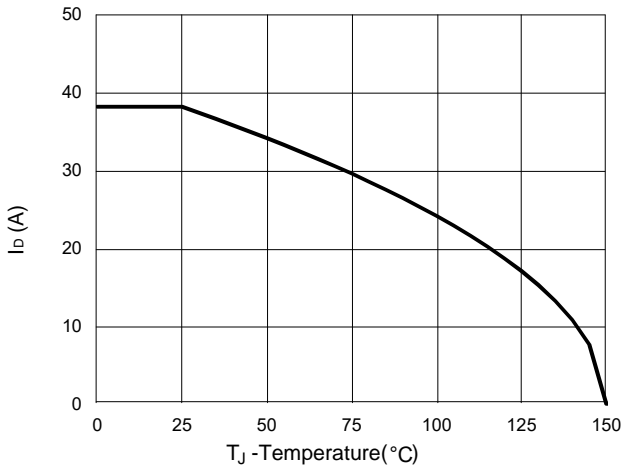

Figure 7: Current De-rating

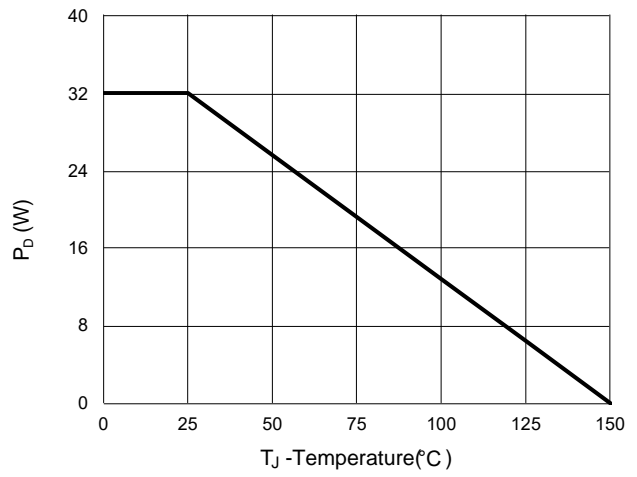

Figure 8: Power Derating

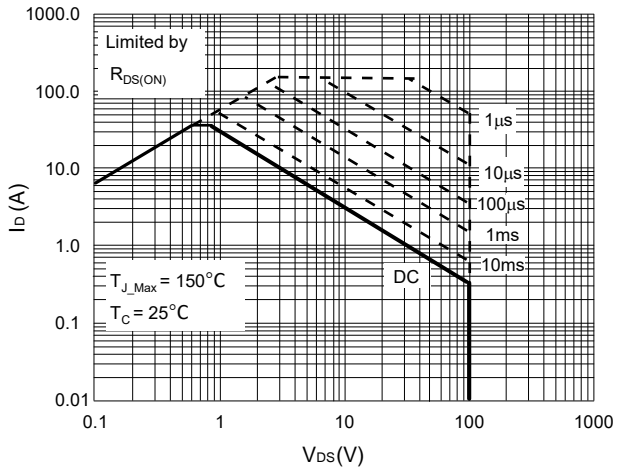
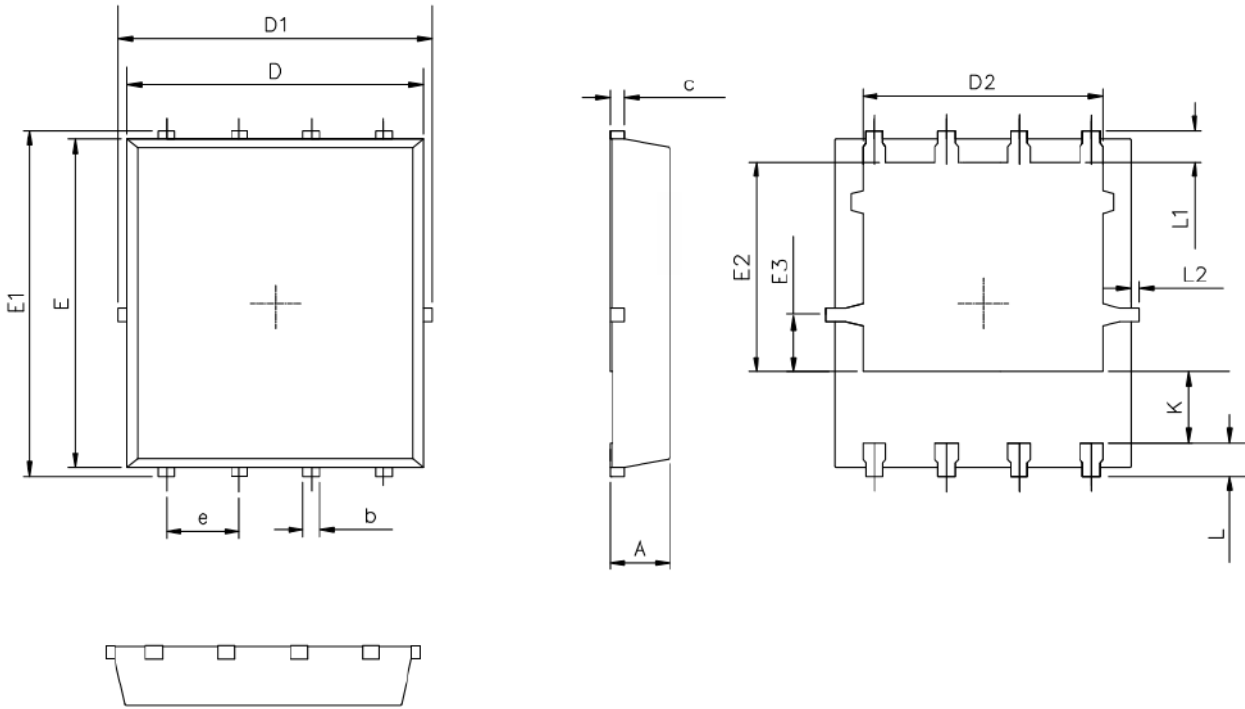
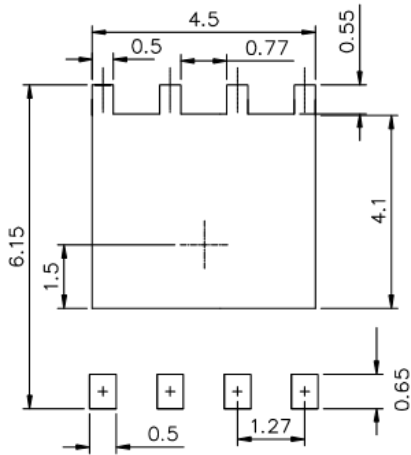

Figure 9: Maximum Safe Operating Area

■ PDFN5X6 PACKAGE OUTLINE DIMENSIONS



RECOMMENDED LAND PATTERN



UNIT:mm

	MIN	NOM	MAX
A	0.90	1.00	1.10
b	0.25	0.35	0.50
c	0.10	0.20	0.30
D	4.80	5.00	5.30
D1	4.90	5.10	5.50
D2	3.92	4.02	4.20
E	5.65	5.75	5.85
E1	5.90	6.05	6.20
E2	3.325	3.525	3.775
E3	0.80	0.90	1.00
e		1.27	
L	0.40	0.55	0.70
L1		0.65	
L2	0.00		0.15
K	1.00	1.30	1.50