

**PRODUCT CHARACTERISTICS**

VDSS	-20V
$R_{DS(on)Typ}@V_{GS}=-4.5V$	33m $\Omega$
$R_{DS(on)Typ}@V_{GS}=-2.5V$	42m $\Omega$
ID	-6A

**APPLICATIONS**

- Load switch for portable
- DC/DC converter

**FEATURES**

- \* High Density Cell Design For Ultra Low On-Resistance
- \* Advanced trench process technology

**ORDER INFORMATION**

Order codes		Package	Packing
Halogen-Free	Halogen		
N/A	MOT2305CB2	SOT-23	3000pieces/Reel

**ABSOLUTE MAXIMUM RATINGS( $T_A=25^{\circ}C$ , unless otherwise specified)**

PARAMETER	SYMBOL	RATING	UNITS
Drain-Source Voltage	$V_{DS}$	-20	V
Gate-Source Voltage	$V_{GS}$	$\pm 12$	V
Continuous Drain Current	$I_D$	-6	A
Pulsed Drain Current	$I_{DM}$	-12	A
Power Dissipation	$P_D$	1.83	W
Junction to Ambient	$\theta_{JA}$	150	$^{\circ}C/W$
Junction Temperature	$T_J$	+150	$^{\circ}C$
Storage Temperature	$T_{STG}$	-55 ~ +150	$^{\circ}C$

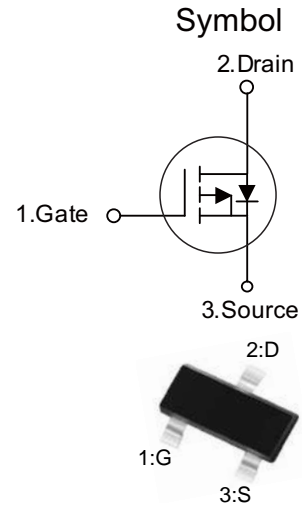

■ ELECTRICAL CHARACTERISTICS ( $T_J=25^{\circ}\text{C}$ , unless otherwise specified)

PARAMETER	SYMBOL	TEST CONDITIONS	MIN	TYP	MAX	UNIT
Of characteristics						
Drain-Source Breakdown Voltage	$BV_{DSS}$	$V_{GS}=0V, I_D=-250\mu A$	-20	-	-	V
Drain-Source Leakage Current	$I_{DSS}$	$V_{DS}=-20V, V_{GS}=0V$	-	-	-1	$\mu A$
Gate-Source Leakage Current	$I_{GSS}$	$V_{GS}=\pm 8V, V_{DS}=0V$	-	-	$\pm 100$	nA
On characteristics						
Gate Threshold Voltage	$V_{GS(TH)}$	$V_{DS}=V_{GS}, I_D=-250\mu A$	-0.45	-	-1.2	V
Drain-Source On-State Resistance	$R_{DS(ON)}$	$V_{GS}=-4.5V, I_D=-4.2A$	-	33	40	m $\Omega$
		$V_{GS}=-2.5V, I_D=-3.4A$	-	42	55	m $\Omega$
Dynamic characteristics						
Input Capacitance	$C_{ISS}$	$V_{GS}=0V, V_{DS}=-20V, f=1\text{MHz}$	-	932	-	pF
Output Capacitance	$C_{OSS}$		-	100	-	pF
Reverse Transfer Capacitance	$C_{RSS}$		-	87	-	pF
Switching characteristics						
Total Gate Charge	$Q_G$	$V_{DS}=-4V, V_{GS}=-4.5V, I_D=-3.5A$	-	12.5	-	nC
Gate-Source Charge	$Q_{GS}$		-	2.5	-	nC
Gate-Drain Charge	$Q_{GD}$		-	1.8	-	nC
Turn-ON Delay Time	$t_{D(ON)}$	$V_{DS}=-4V, V_{GS}=-4.5V, I_D=-1A, R_G=6\Omega, R_D=4\Omega$	-	10	-	ns
Turn-ON Rise Time	$t_R$		-	39	-	ns
Turn-OFF Delay Time	$t_{D(OFF)}$		-	42	-	ns
Turn-OFF Fall Time	$t_F$		-	28	-	ns
Source-drain diode ratings and characteristics						
Maximum Continuous Forward Current	$I_S$		-	-	-4.2	A
Maximum Pulsed Forward Current	$I_{SM}$		-	-	-10	A
Drain-Source Diode Forward Voltage	$V_{SD}$	$V_{GS}=0V, I_S=-1.2A$	-	-	-1.2	V

■ TYPICAL CHARACTERISTICS

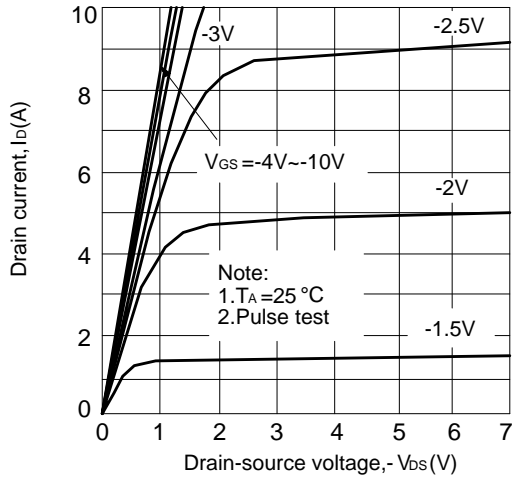

Figure 1: Drain current vs. drain-source voltage

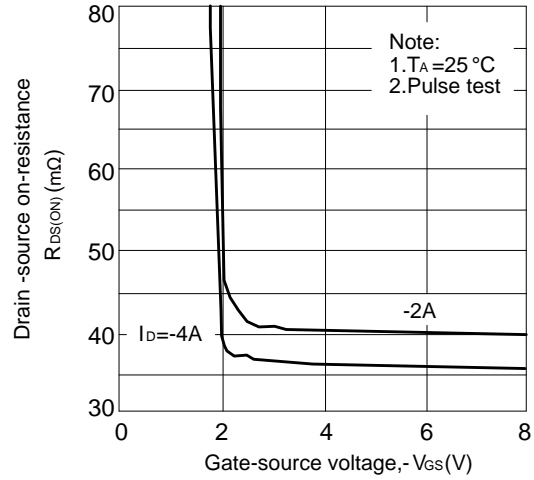

Figure 2: Drain-source on-resistance vs. gate-source voltage

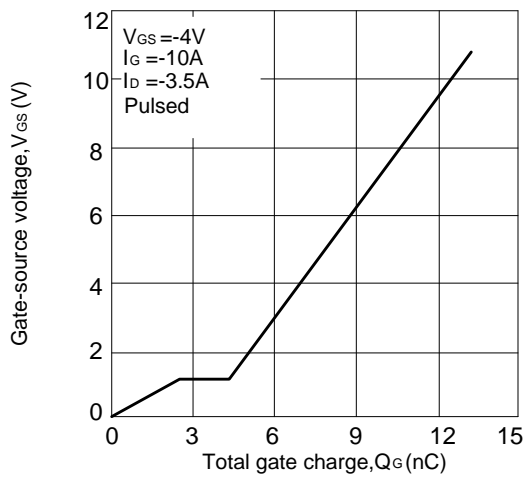

Figure 3: Gate charge characteristics

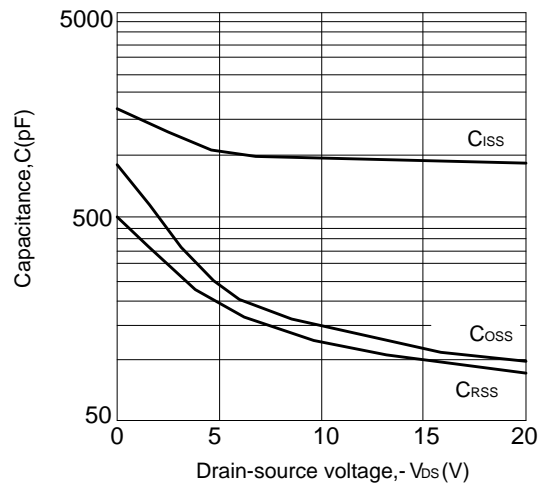

Figure 4: Capacitance characteristics

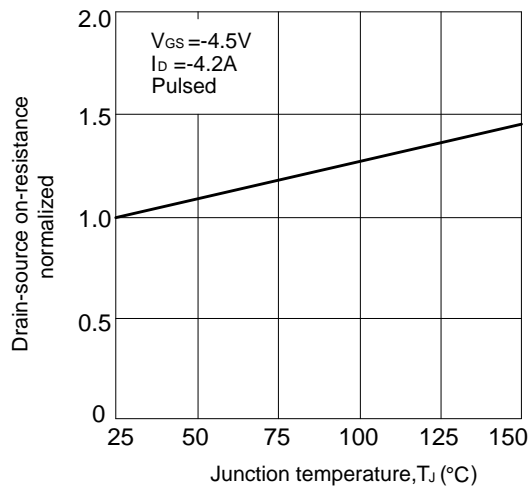

Figure 5: Drain-source on-resistance vs junction temperature

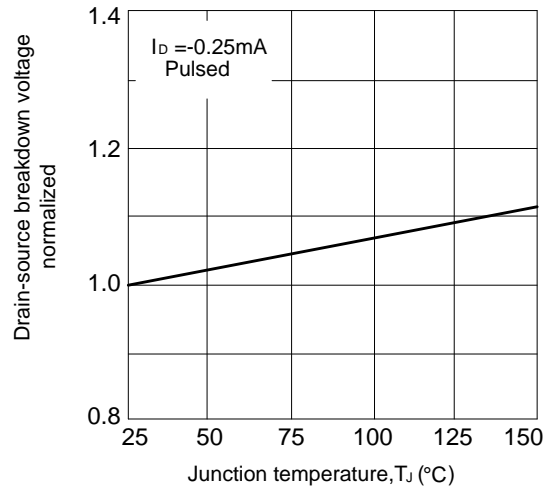

Figure 6: Breakdown voltage vs. junction temperature

■ TYPICAL CHARACTERISTICS(Cont.)

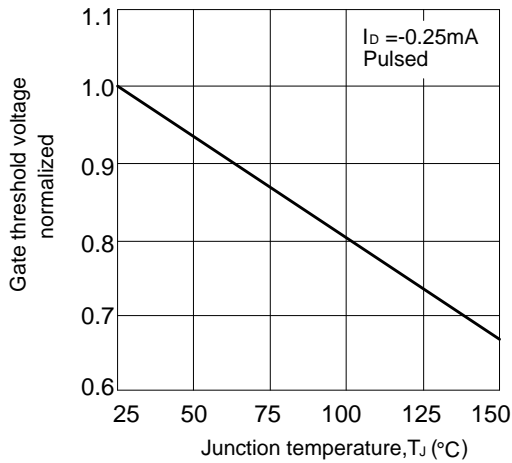

Figure 7: Gate threshold voltage vs. junction temperature

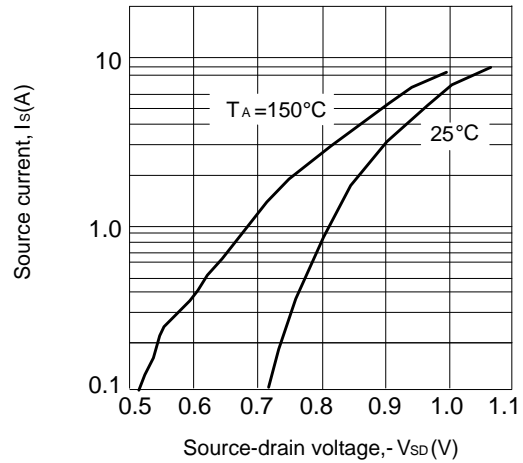

Figure 8: Source current vs. source-drain Voltage

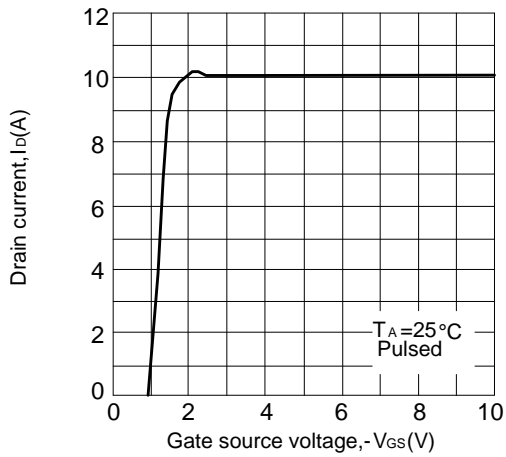

Figure 9: Drain current vs. gate-source voltage

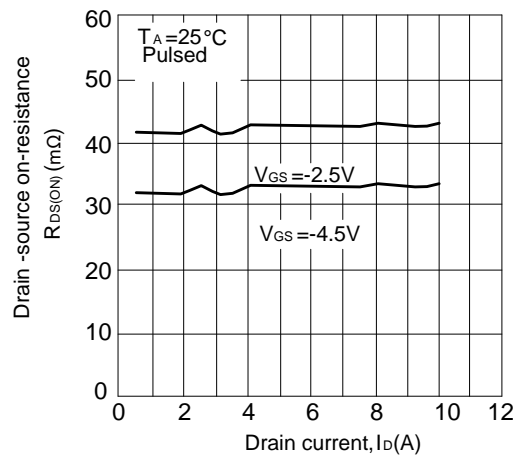

Figure 10: Drain-source on-resistance vs. drain current

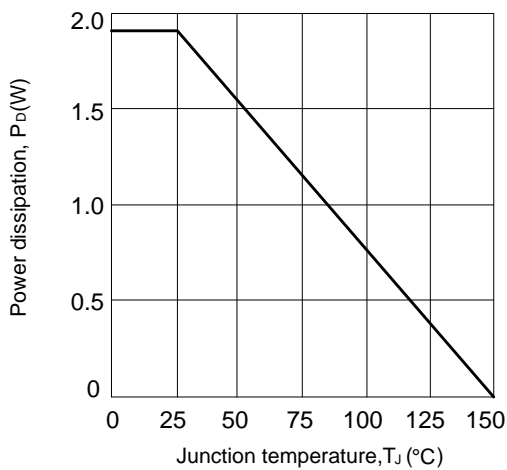

Figure 11: Power dissipation vs. junction temperature

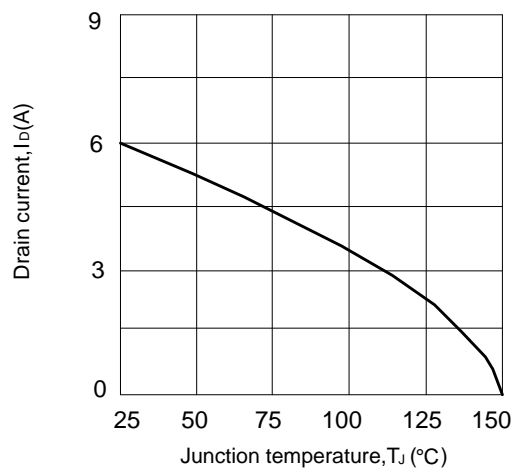
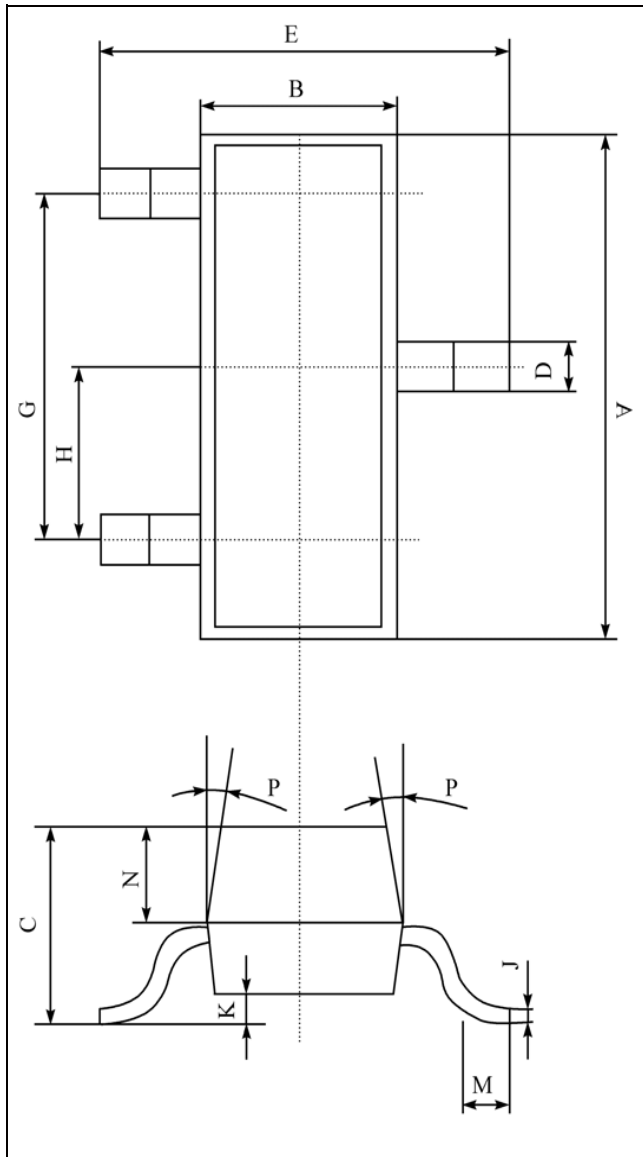

Figure 12: Drain current vs. junction temperature

■ SOT-23 PACKAGE OUTLINE DIMENSIONS

单位 (UNIT) : mm



序号	数值及公差
A	2.90±0.10
B	1.30±0.10
C	1.00±0.10
D	0.40±0.10
E	2.40±0.20
G	1.90±0.10
H	0.95±0.05
J	0.13±0.05
K	0.00-0.10
M	≥0.20
N	0.60±0.10
P	7±2°
Packing SOT-23 包装规格 SMD片式表面贴封装 包装方式: 载带卷盘包装 Tape & Reel, 3Kpcs/Reel 每卷数量3000只 (3Kpcs/Reel) 每盒数量45000只 (45Kpcs/BOX) 每箱数量180000只 (180Kpcs/Cartons)	

■ SOT-23 Embossed Carrier Tape

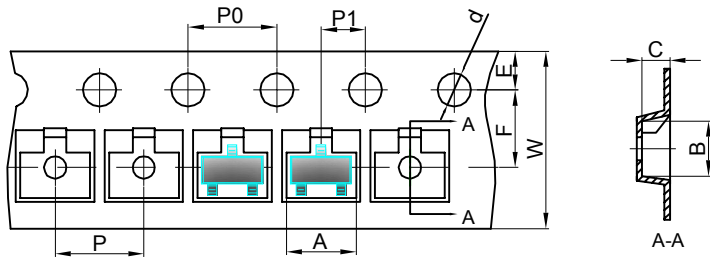

Dimensions are in millimeter										
Pkg type	A	B	C	d	E	F	P0	P	P1	W
SOT-23	3.15	2.77	1.22	Ø1.50	1.75	3.50	4.00	4.00	2.00	8.00

SOT-23 Tape Leader and Trailer

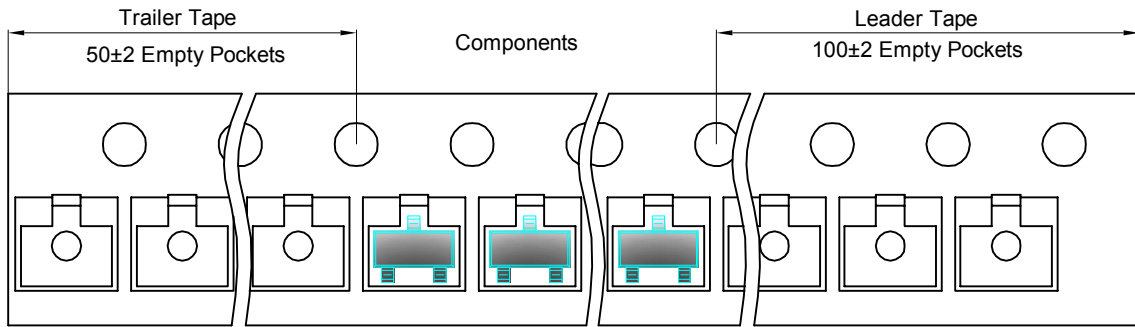

SOT-23 Reel

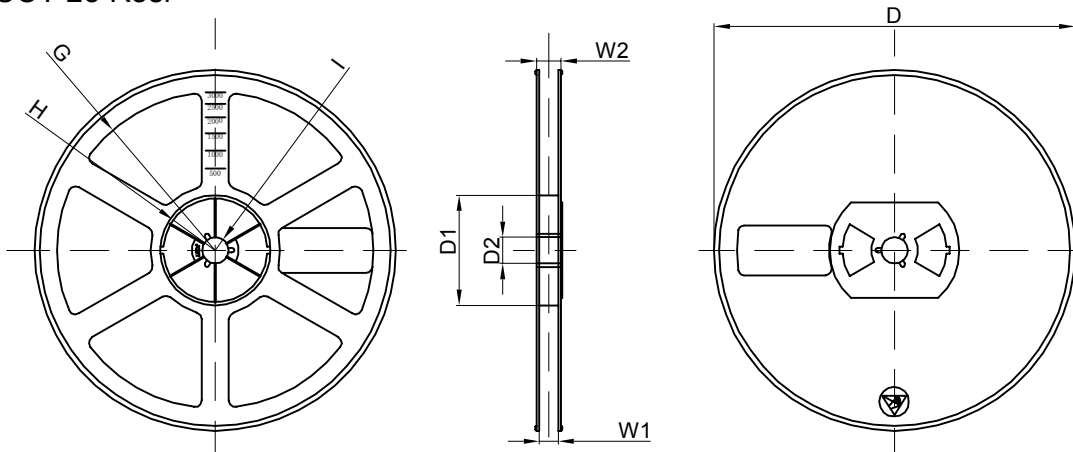

Dimensions are in millimeter								
Reel Option	D	D1	D2	G	H	I	W1	W2
7" Dia	Ø178.00	54.40	13.00	R78.00	R25.60	R6.50	9.50	12.30

REEL	Reel Size	Box	Box Size(mm)	Carton	Carton Size(mm)	G.W.(kg)
3000 pcs	7 inch	45,000 pcs	192×192×193	180,000 pcs	404×404×214	