

■ PRODUCT CHARACTERISTICS

V _{DSS}	500V
R _{DS(ON)} Typ(@V _{GS} =10V)	0.167Ω
Q _g @typ	102nC
I _D	28A

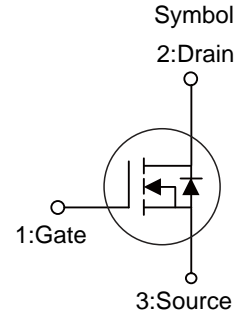

■ APPLICATIONS

- * High efficiency switch mode power supplies
- * Electronic lamp ballasts based on half bridge
- * LED power supplies

■ FEATURE

- * High Switching Speed
- * Improved dv/dt capability

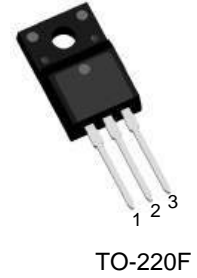

■ ORDER INFORMATION

Order Codes		Package	Packing
Halogen-Free	Halogen		
N/A	MOT28N50HF	TO-220F	50 pieces/Tube

■ ABSOLUTE MAXIMUM RATINGS(T_A =25°C, unless otherwise specified)

Parameter	Symbol	Ratings	Unit
Drain-Source Voltage	V _{DSS}	500	V
Gate-Source Voltage	V _{GSS}	±30	V
Drain Current Continuous(@V _{GS} =10V, T _A =25°C)	I _D	28	A
Drain Current Pulsed	I _{DM}	112	A
Avalanche Energy *	E _{AS}	2600	mJ
Peak Diode Recovery dv/dt	dv/dt	5.0	V/ns
Power Dissipation	P _D	55	W
Junction Temperature	T _J	+150	°C
Storage Temperature	T _{STG}	-55~ +150	°C

■ THERMAL CHARACTERISTICS

Parameter	Symbol	Typ	Unit
Junction to Ambient	R _{thJA}	62.5	°C/W
Junction to Case	R _{thJC}	2.27	°C/W

Note: * EAS condition: T_J=25°C, V_{DD}=50V, V_G=10V, L=10mH, R_g=25Ω

■ ELECTRICAL CHARACTERISTICS ($T_C=25^{\circ}\text{C}$, unless otherwise noted)

Parameter	Symbol	Test Conditions	Min	Typ	Max	Unit
Off characteristics						
Drain to Source Breakdown Voltage	V_{DSS}	$V_{GS}=0V, I_D=250\mu A$	500	-	-	V
Drain to Source Leakage Current	I_{DSS}	$V_{DS}=500V, V_{GS}=0V$	-	-	1	μA
Gate to Source Forward Leakage	$I_{GSS(F)}$	$V_{DS}=0V, V_{GS}=+30V$	-	-	100	nA
Gate to Source Reverse Leakage	$I_{GSS(R)}$	$V_{DS}=0V, V_{GS}=-30V$	-	-	-100	nA
On characteristics						
Drain to Source On-Resistance	$R_{DS(ON)}$	$V_{GS}=10V, I_D=14A$	-	0.167	0.2	Ω
Gate Threshold Voltage	$V_{GS(TH)}$	$V_{DS}=V_{GS}, I_D=250\mu A$	2	-	4	V
Dynamic characteristics						
Gate capacitance	R_g	$V_{GS}=0V, V_{DS}=0V, f=1.0\text{MHz}$	-	1.7	-	Ω
Forward Transconductance	g_{fs}	$V_{DS}=10V, I_D=3A$	-	11	-	S
Input Capacitance	C_{iss}	$V_{DS}=25V, V_{GS}=0V$ $f=1.0\text{MHz}$	-	4400	-	pF
Output Capacitance	C_{oss}		-	375	-	pF
Reverse Transfer Capacitance	C_{rss}		-	2.1	-	pF
Resistive Switching Characteristics						
Turn-on Delay Time	$t_{d(ON)}$	$I_D=28A, V_{DS}=250V$ $R_G=25\Omega, V_{GS}=10V$	-	45	-	ns
Rise Time	t_r		-	87	-	ns
Turn-off Delay Time	$t_{d(OFF)}$		-	355	-	ns
Fall Time	t_f		-	130	-	ns
Total Gate Charge	Q_g	$I_D=28A, V_{DS}=250V$ $V_{GS}=10V$	-	102	-	nC
Gate to Source Charge	Q_{gs}		-	43	-	nC
Gate to Drain("Miller") Charge	Q_{gd}		-	20	-	nC
Source-Drain Diode Characteristics						
Continuous Source Current(Body Diode)	I_S		-	-	28	A
Maximum Pulsed Current(Body Diode)	I_{SM}		-	-	112	A
Diode Forward Voltage	V_{SD}	$I_{SD}=1A, V_{GS}=0V$	-	0.72	1.2	V
Reverse Recovery Time	t_{rr}	$I_{SD}=28A, T_J=25^{\circ}\text{C}$	-	656	-	ns
Reverse Recovery Charge	Q_{rr}	$di/dt=100A/\mu s$	-	8740	-	nC

■ TYPICAL CHARACTERISTICS

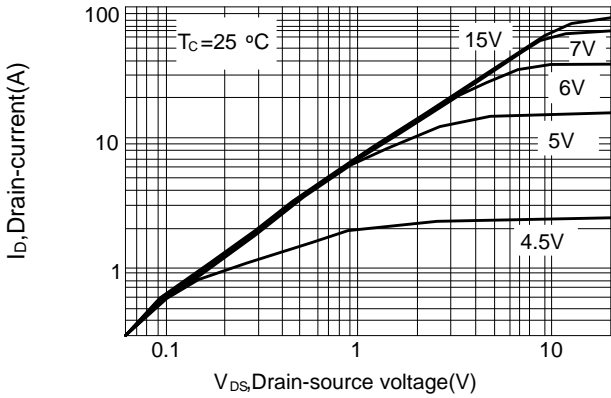

Figure 1: Output characteristics

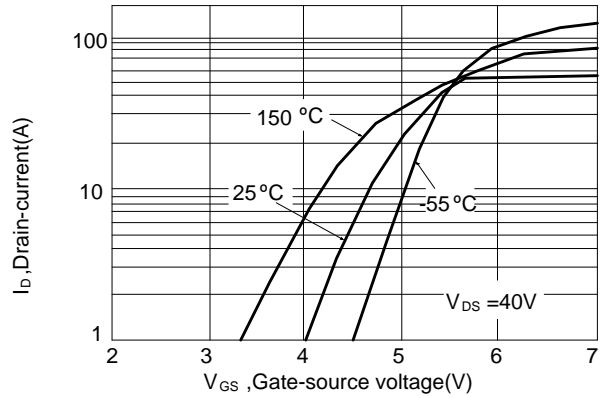

Figure 2: Transfer characteristics

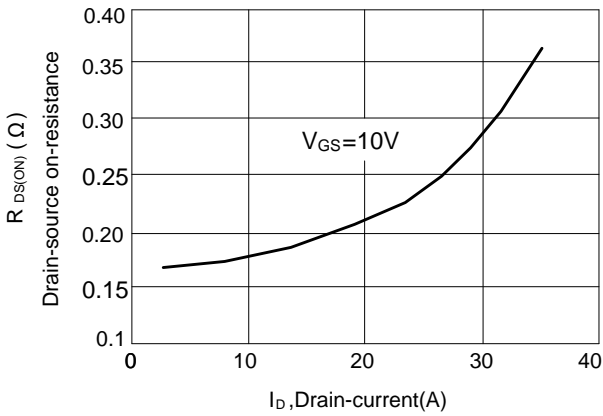

Figure 3: Drain to Source On-resistance
Drain Current

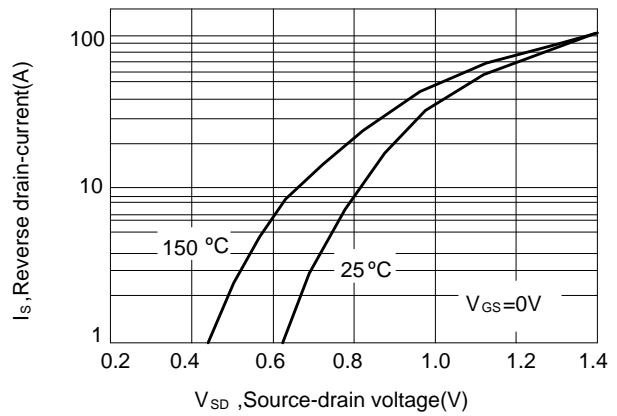

Figure 4: Body diode characteristics

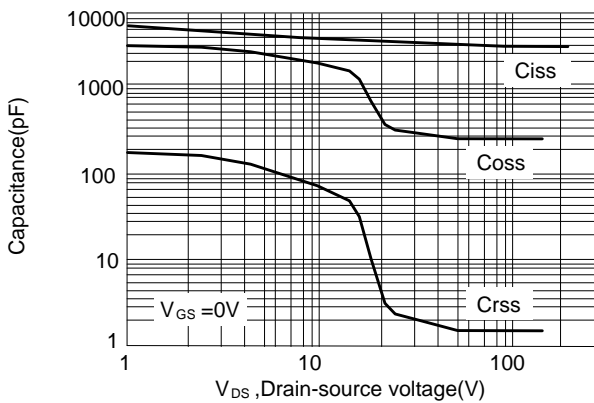

Figure 5: Capacitance characteristics

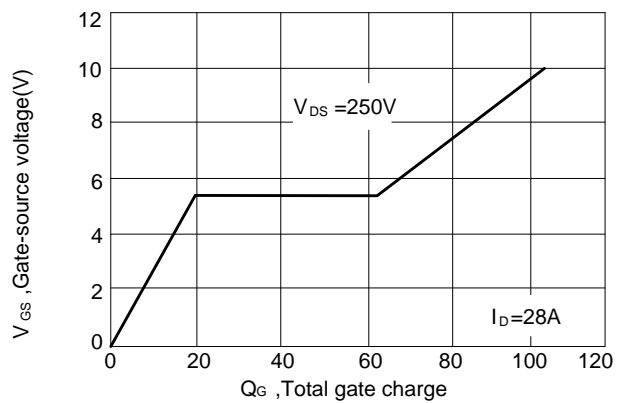

Figure 6: Gate charge characteristics

■ TYPICAL CHARACTERISTICS(Cont.)

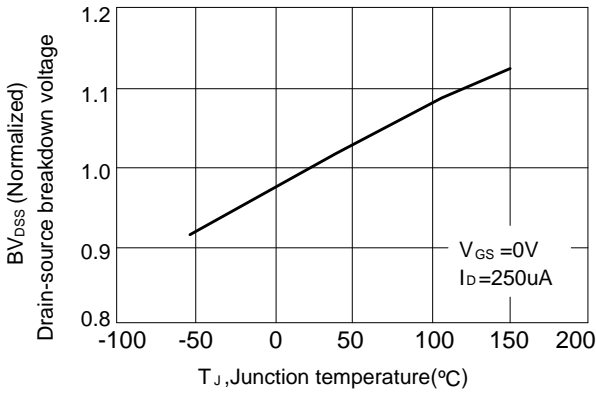

Figure 7: Breakdown voltage variation vs temperature

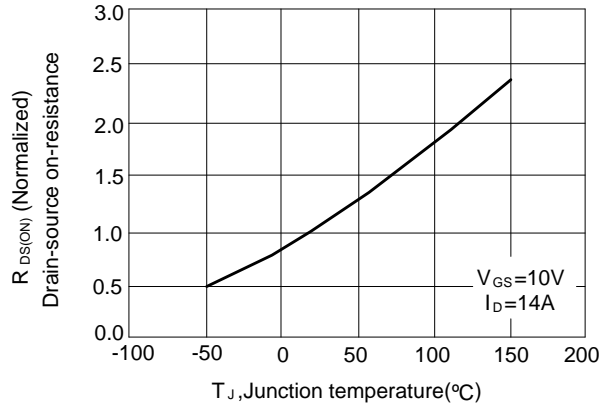

Figure 8: On-resistance variation vs temperature

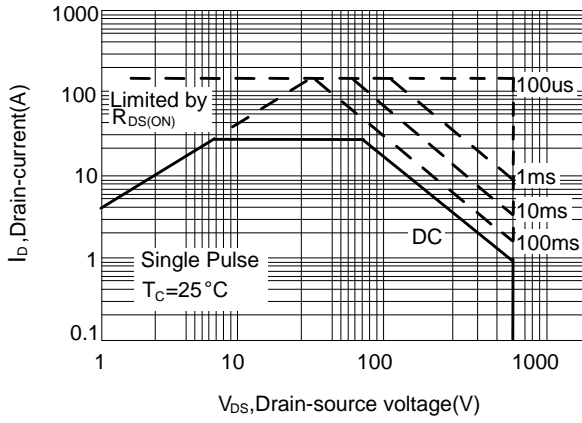

Figure 9: Maximum safe operation area

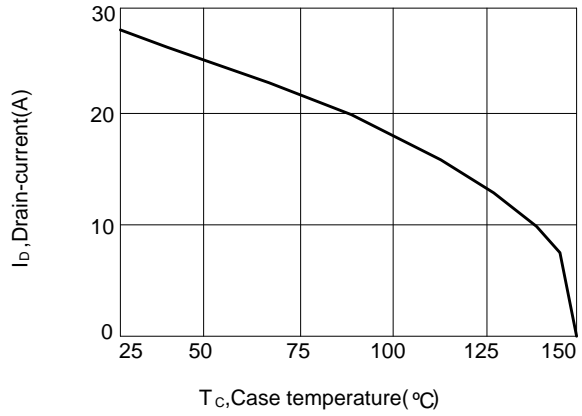

Figure 10: On-resistance variation

■ TO-220F PACKAGE OUTLINE DIMENSIONS

