

■ PRODUCT CHARACTERISTICS

$V_{DSS}$	30V
$R_{DS(ON)}$ Typ(@ $V_{GS}=10V$ )	1.4m $\Omega$
$R_{DS(ON)}$ Typ(@ $V_{GS}=4.5V$ )	1.8m $\Omega$
$I_D$	170A

■ APPLICATIONS

- \* Motor Control
- \* High Performance SMPS
- \* DC/DC Converter

■ FEATURE

- \* Low Gate Charge
- \* Ultra-low RDS(ON)

■ ORDER INFORMATION

Order Codes		Package	Packing
Halogen-Free	Halogen		
N/A	MOT3114G	PDFN5X6	5000 pieces/Reel

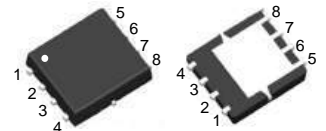
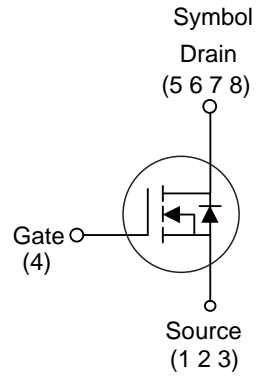

PDFN5X6



■ ABSOLUTE MAXIMUM RATINGS( $T_A=25^{\circ}C$ , unless otherwise specified)

Parameter	Symbol	Ratings	Unit
Drain-Source Voltage	$V_{DSS}$	30	V
Gate-Source Voltage	$V_{GSS}$	$\pm 20$	V
Drain Current Continuous(@ $V_{GS}=10V, T_A=25^{\circ}C$ )	$I_D$	170	A
Drain Current Pulsed	$I_{DM}$	680	A
Avalanche Energy *	$E_{AS}$	650	mJ
Power Dissipation	$P_D$	88	W
Junction Temperature	$T_J$	+150	$^{\circ}C$
Storage Temperature	$T_{STG}$	-55~ +150	$^{\circ}C$

■ THERMAL CHARACTERISTICS

Parameter	Symbol	Typ	Unit
Junction to Case	$R_{thJC}$	1.42	$^{\circ}C/W$

Note: \* EAS condition:  $T_J=25^{\circ}C, V_{DD}=24V, V_G=10V, L=0.5mH, R_g=25\Omega$

**■ ELECTRICAL CHARACTERISTICS** ( $T_C=25^\circ\text{C}$ , unless otherwise noted)

Parameter	Symbol	Test Conditions	Min	Typ	Max	Unit
Off characteristics						
Drain to Source Breakdown Voltage	$V_{DSS}$	$V_{GS}=0V, I_D=250\mu A$	30	-	-	V
Drain to Source Leakage Current	$I_{DSS}$	$V_{DS}=300V, V_{GS}=0V$	-	-	1	$\mu A$
Gate to Source Forward Leakage	$I_{GSS(F)}$	$V_{DS}=0V, V_{GS}=+20V$	-	-	100	nA
Gate to Source Reverse Leakage	$I_{GSS(R)}$	$V_{DS}=0V, V_{GS}=-20V$	-	-	-100	nA
On characteristics						
Drain to Source On-Resistance	$R_{DS(ON)}$	$V_{GS}=10V, I_D=20A$	-	1.4	1.65	$m\Omega$
		$V_{GS}=4.5V, I_D=20A$	-	1.8	2.2	$m\Omega$
Gate Threshold Voltage	$V_{GS(TH)}$	$V_{DS}=V_{GS}, I_D=250\mu A$	1	1.5	2.5	V
Dynamic characteristics						
Gate capacitance	$R_g$	$V_{GS}=0V, V_{DS}=0V, f=1.0MHz$	-	1.3	-	$\Omega$
Forward Transconductance	$g_{fs}$	$V_{DS}=10V, I_D=3A$	10	-	-	S
Input Capacitance	$C_{iss}$	$V_{DS}=20V, V_{GS}=0V$ $f=1.0MHz$	-	6100	-	pF
Output Capacitance	$C_{oss}$		-	580	-	pF
Reverse Transfer Capacitance	$C_{rss}$		-	530	-	pF
Resistive Switching Characteristics						
Turn-on Delay Time	$t_{d(ON)}$	$I_D=85A, V_{DS}=15V$ $R_G=1.6\Omega, V_{GS}=10V$	-	13	-	ns
Rise Time	$t_r$		-	7.3	-	ns
Turn-off Delay Time	$t_{d(OFF)}$		-	51	-	ns
Fall Time	$t_f$		-	86	-	ns
Total Gate Charge	$Q_g$	$I_D=85A, V_{DS}=15V$ $V_{GS}=10V$	-	98	-	nC
Gate to Source Charge	$Q_{gs}$		-	16	-	nC
Gate to Drain("Miller") Charge	$Q_{gd}$		-	11	-	nC
Source-Drain Diode Characteristics						
Continuous Source Current(Body Diode)	$I_S$		-	-	170	A
Maximum Pulsed Current(Body Diode)	$I_{SM}$		-	-	680	A
Diode Forward Voltage	$V_{SD}$	$I_{SD}=1A, V_{GS}=0V$	-	0.71	1.2	V
Reverse Recovery Time	$t_{rr}$	$I_{SD}=85A, T_J=25^\circ\text{C}$ $di/dt=100A/\mu s$	-	32	-	ns
Reverse Recovery Charge	$Q_{rr}$		-	112	-	nC

■ TYPICAL CHARACTERISTICS

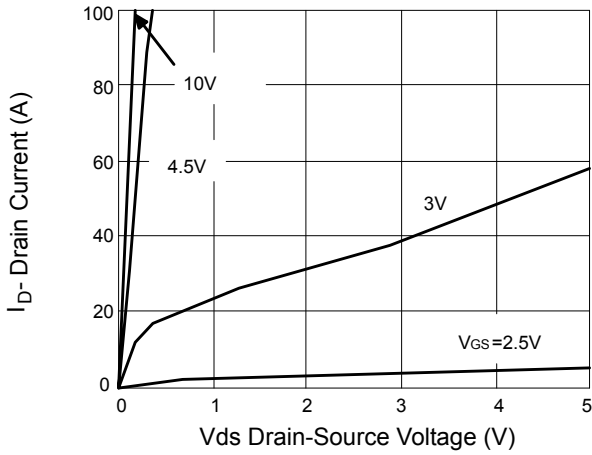

Figure 1 Output characteristics

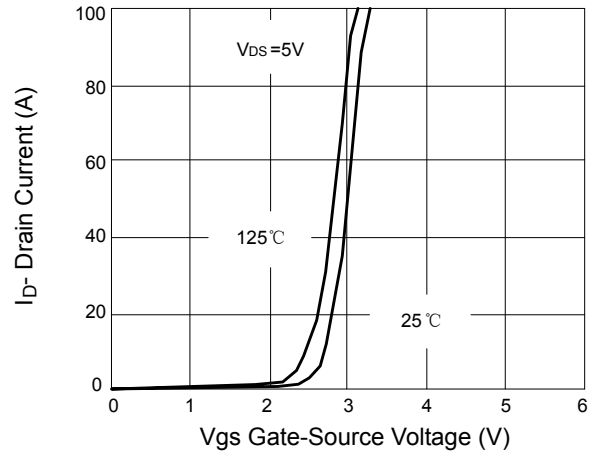

Figure 2 Transfer characteristics

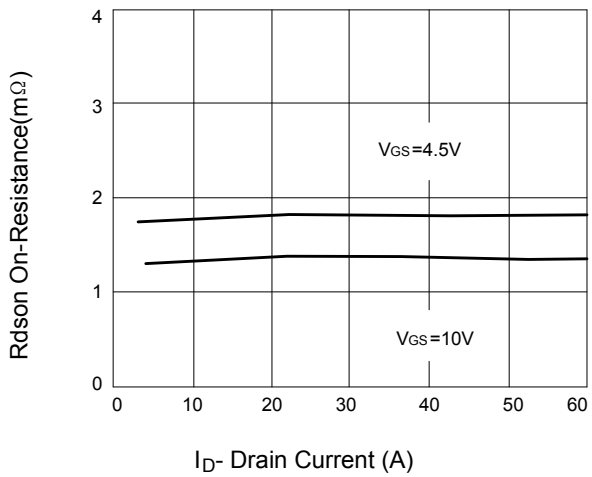

Figure 3 Rdson-drain current

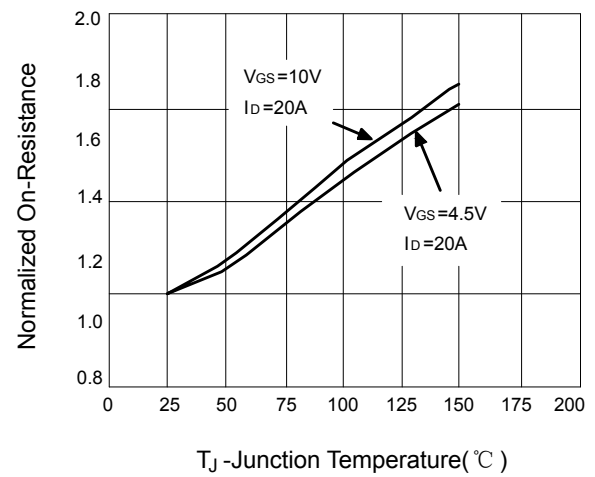

Figure 4 Rdson-junction temperature

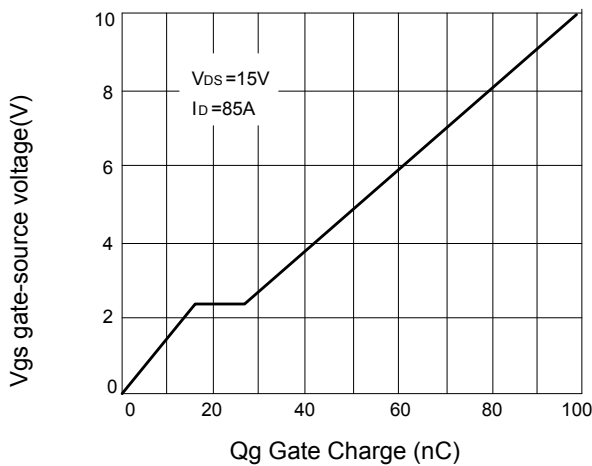

Figure 5 Gate charge

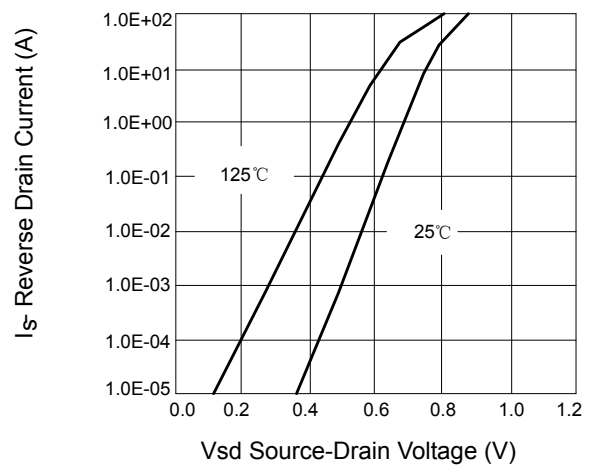

Figure 6 Source-drain diode forward

■ TYPICAL CHARACTERISTICS(Cont.)

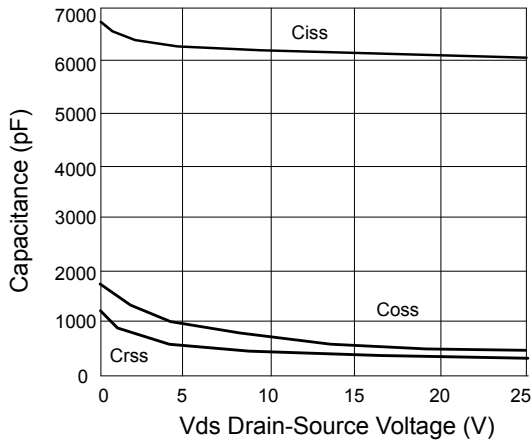

Figure 7 Capacitance vs. vds

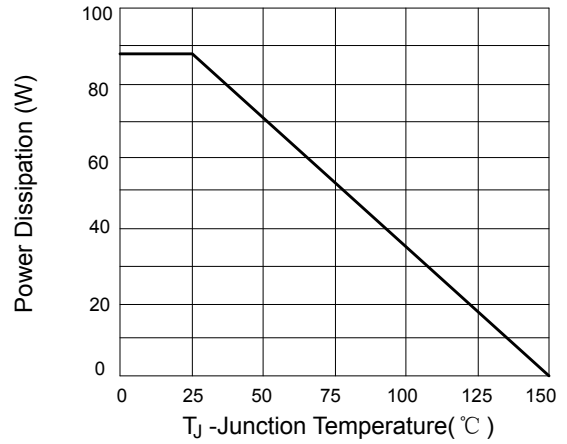

Figure 8 Power de-rating

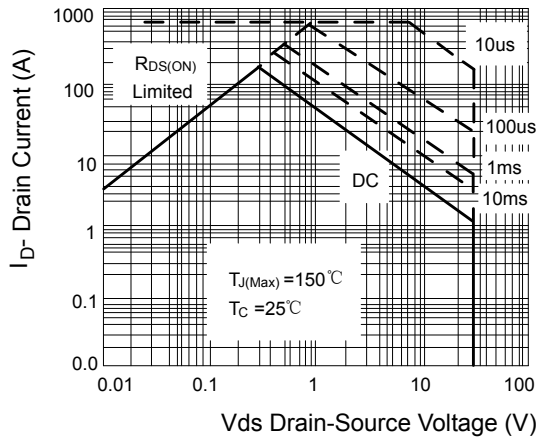

Figure 9 Safe operation area

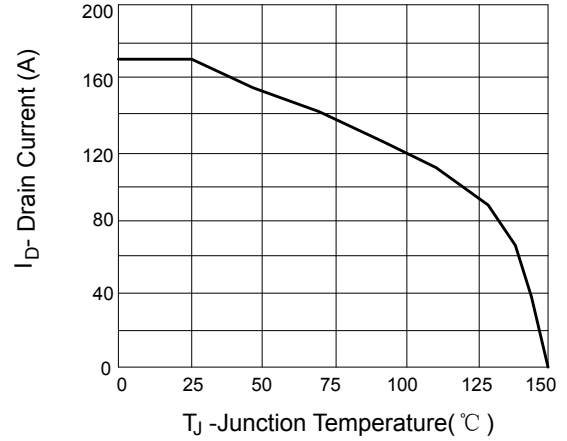
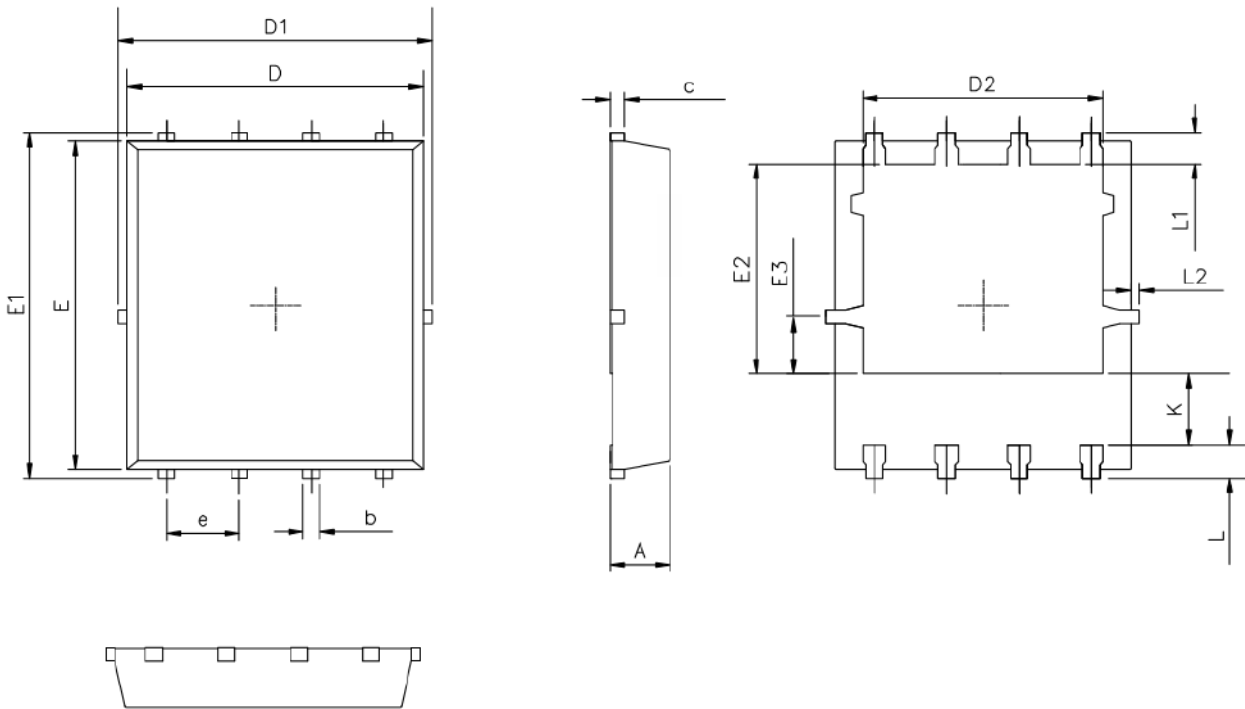
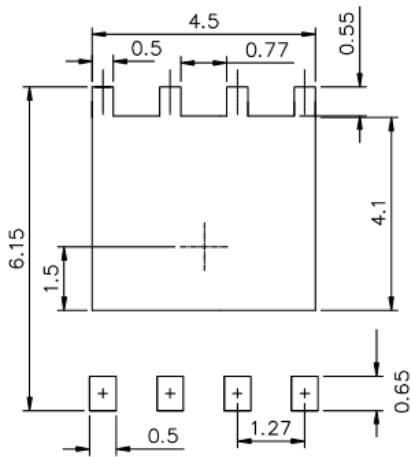

Figure 10 Power de-rating

■ PDFN5X6 PACKAGE OUTLINE DIMENSIONS



RECOMMENDED LAND PATTERN



UNIT:mm

	MIN	NOM	MAX
A	0.90	1.00	1.10
b	0.25	0.35	0.50
c	0.10	0.20	0.30
D	4.80	5.00	5.30
D1	4.90	5.10	5.50
D2	3.92	4.02	4.20
E	5.65	5.75	5.85
E1	5.90	6.05	6.20
E2	3.325	3.525	3.775
E3	0.80	0.90	1.00
e		1.27	
L	0.40	0.55	0.70
L1		0.65	
L2	0.00		0.15
K	1.00	1.30	1.50