

■ PRODUCT CHARACTERISTICS

$V_{DSS}$	30V
$R_{DS(ON) Typ(@V_{GS}=10V)}$	4.3m $\Omega$
$R_{DS(ON) Typ(@V_{GS}=4.5V)}$	7m $\Omega$
$I_D$	80A

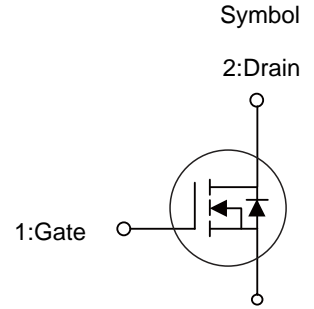

■ APPLICATIONS

- \* Electronic lamp ballasts based on half bridge
- \* Load Switching, Quick/Wireless Charge.
- \* Motor Driving

■ FEATURE

- \* Low Gate Charge
- \* Pb-Free Lead Plating



TO-252

■ ORDER INFORMATION

Order Codes		Package	Packing
Halogen-Free	Halogen		
N/A	MOT80N03XD	TO-252	2500 pieces/Reel

■ ABSOLUTE MAXIMUM RATINGS( $T_A=25^{\circ}C$ , unless otherwise specified)

Parameter	Symbol	Ratings	Unit
Drain-Source Voltage	$V_{DSS}$	30	V
Gate-Source Voltage	$V_{GSS}$	$\pm 20$	V
Drain Current Continuous(@ $V_{GS}=10V, T_A=25^{\circ}C$ )	$I_D$	80	A
Drain Current Continuous(@ $V_{GS}=10V, T_A=100^{\circ}C$ )	$I_D$	58	A
Drain Current Pulsed	$I_{DM}$	320	A
Avalanche Energy *	$E_{AS}$	156	mJ
Power Dissipation	$P_D$	78	W
Junction Temperature	$T_J$	+150	$^{\circ}C$
Storage Temperature	$T_{STG}$	-55~ +150	$^{\circ}C$

■ THERMAL CHARACTERISTICS

Parameter	Symbol	Typ	Unit
Junction to Case	$R_{thJC}$	1.6	$^{\circ}C/W$

Note: \* EAS condition:  $T_J=25^{\circ}C, V_{DD}=20V, V_G=10V, L=0.5mH, R_g=25\Omega$

**■ ELECTRICAL CHARACTERISTICS** ( $T_C=25^{\circ}\text{C}$ , unless otherwise noted)

Parameter	Symbol	Test Conditions	Min	Typ	Max	Unit
<b>Off characteristics</b>						
Drain to Source Breakdown Voltage	$V_{DSS}$	$V_{GS}=0V, I_D=250\mu A$	30	-	-	V
Drain to Source Leakage Current	$I_{DSS}$	$V_{DS}=30V, V_{GS}=0V$	-	-	1	$\mu A$
Gate to Source Forward Leakage	$I_{GSS(F)}$	$V_{GS}=+20V, V_{DS}=0V$	-	-	100	nA
Gate to Source Reverse Leakage	$I_{GSS(R)}$	$V_{GS}=-20V, V_{DS}=0V$	-	-	-100	nA
<b>On characteristics</b>						
Drain to Source On-Resistance	$R_{DS(ON)}$	$V_{GS}=10V, I_D=20A$	-	4.3	5.2	m $\Omega$
		$V_{GS}=4.5V, I_D=20A$	-	7	7.8	m $\Omega$
Gate Threshold Voltage	$V_{GS(TH)}$	$V_{DS}=V_{GS}, I_D=250\mu A$	1	1.45	2.5	V
<b>Dynamic characteristics</b>						
Gate Resistance	$R_g$	$V_{GS}=0V, V_{DS}=0V, f=1.0\text{MHz}$	-	1.9	-	$\Omega$
Forward Transconductance	$g_{fs}$	$V_{DS}=10V, I_D=3A$	-	10	-	S
Input Capacitance	$C_{iss}$	$V_{DS}=20V, V_{GS}=0V$ $f=1.0\text{MHz}$	-	1700	-	pF
Output Capacitance	$C_{oss}$		-	160	-	pF
Reverse Transfer Capacitance	$C_{rss}$		-	150	-	pF
<b>Resistive Switching Characteristics</b>						
Turn-on Delay Time	$t_{d(ON)}$	$V_{GS}=10V, V_{DS}=15V,$ $I_D=40A, R_G=2.7\Omega$	-	7	-	ns
Rise Time	$t_r$		-	75	-	ns
Turn-off Delay Time	$t_{d(OFF)}$		-	42	-	ns
Fall Time	$t_f$		-	88	-	ns
Total Gate Charge	$Q_g$	$I_D=40A, V_{DS}=15V$ $V_{GS}=10V$	-	45	-	nC
Gate to Source Charge	$Q_{gs}$		-	8	-	nC
Gate to Drain("Miller") Charge	$Q_{gd}$		-	10	-	nC
<b>Source-Drain Diode Characteristics</b>						
Continuous Source Current(Body Diode)	$I_S$		-	-	80	A
Maximum Pulsed Current(Body Diode)	$I_{SM}$		-	-	320	A
Diode Forward Voltage	$V_{SD}$	$I_{SD}=1A, V_{GS}=0V$	-	0.76	1.2	V
Reverse Recovery Time	$t_{rr}$	$I_{SD}=40A, T_J=25^{\circ}\text{C}$ $di/dt=100A/\mu s$	-	13	-	ns
Reverse Recovery Charge	$Q_{rr}$		-	5	-	nC

■ TYPICAL CHARACTERISTICS

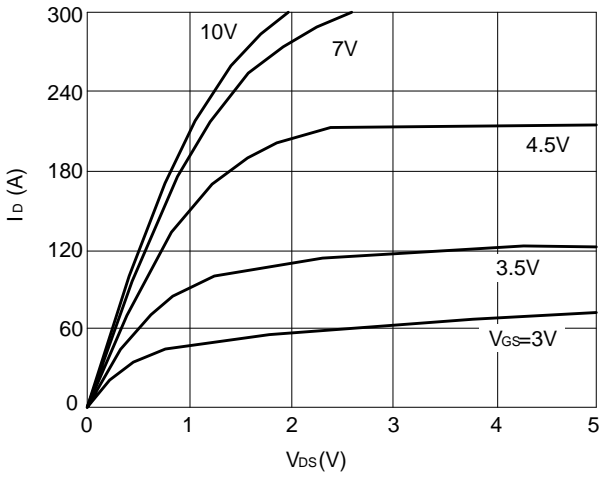

Figure 1: Output Characteristics

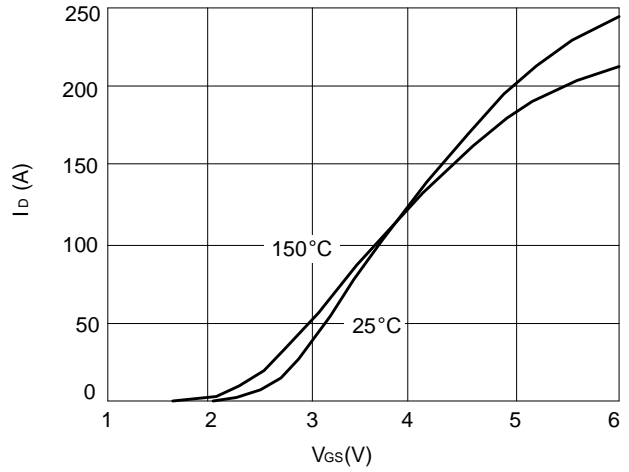

Figure 2: Transfer Characteristics

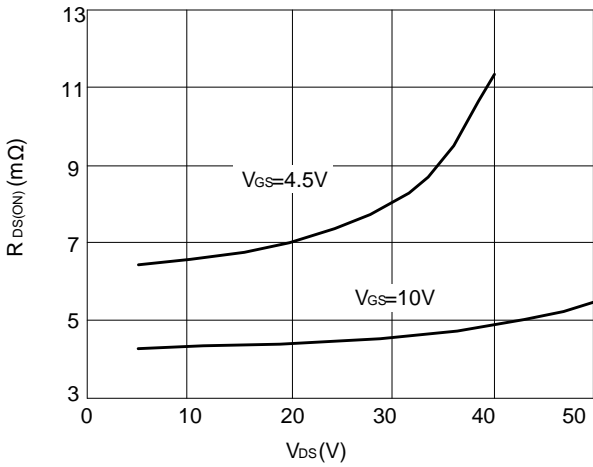

Figure 3: Rds(on) vs. Drain Current and Gate Voltage



Figure 4: Rds(on) vs. Temperature

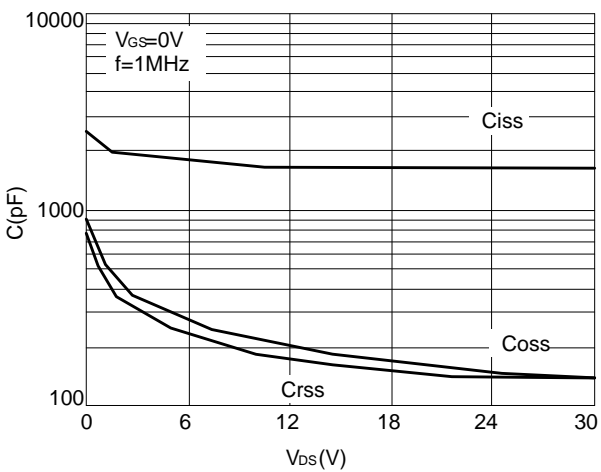

Figure 5: Capacitance Characteristics

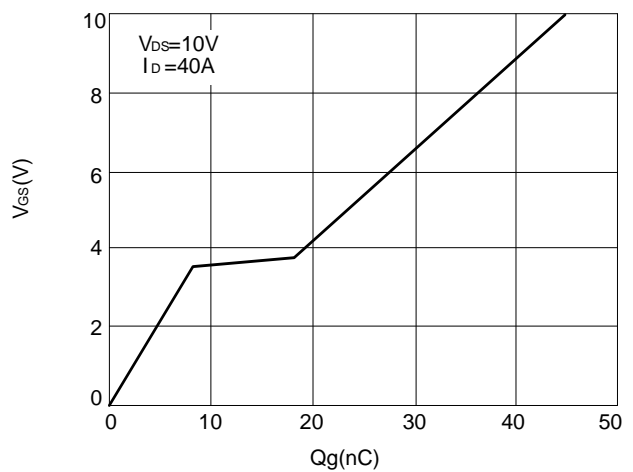

Figure 6: Gate Charge Characteristics

■ TYPICAL CHARACTERISTICS(Cont.)

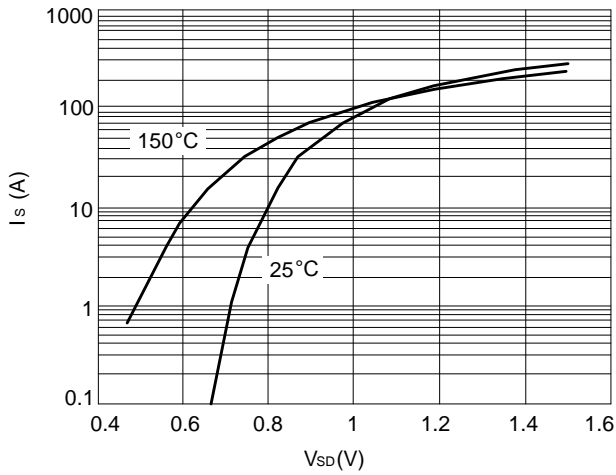

Figure 7: Body Diode Forward Characteristics

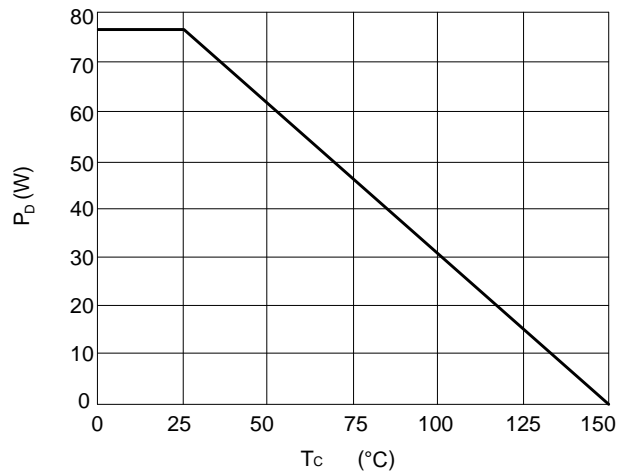

Figure 8: Power Dissipation

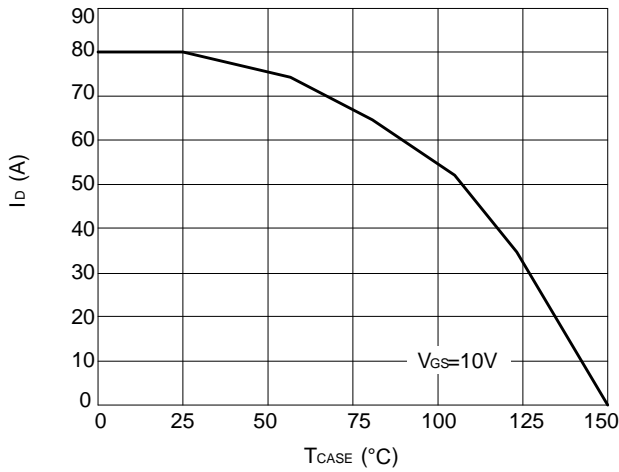

Figure 9: Drain Current Derating

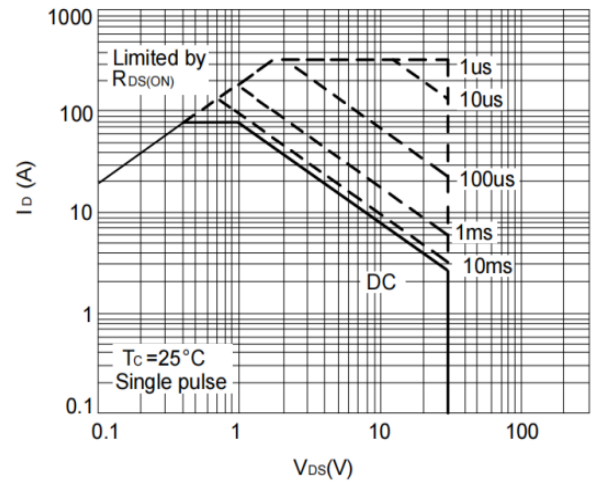

Figure 10: Safe Operating Area

■ TO-252 PACKAGE OUTLINE DIMENSIONS

