

■ PRODUCT CHARACTERISTICS

VDSS	20V
R _{DS(on)} Typ(@V _{GS} =4.5V)	19mΩ
R _{DS(on)} Typ(@V _{GS} =2.5V)	23mΩ
Qg@type	8.4nC
ID	6A

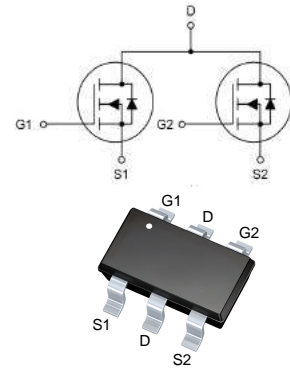

■ FEATURES

- * Fast switching capability
- * Avalanche energy Specified
- * Improved dv/dt capability, high ruggedness

■ ORDER INFORMATION

Order codes		Package	Packing
Halogen-Free	Halogen		
N/A	MOT8205SA6	SOT-23A-6L	3000pieces /Reel

■ ABSOLUTE MAXIMUM RATINGS

PARAMETER	SYMBOL	RATINGS	UNIT	
Drain-Source Voltage	V _{DSS}	20	V	
Gate-Source Voltage	V _{GSS}	±8	V	
Drain Current	Continuous	I _D	6	A
	Pulsed	I _{DM}	24	A
Power Dissipation (T _A =25°C)	P _D	1.14	W	
Junction Temperature	T _J	+150	°C	
Storage Temperature	T _{STG}	-55 ~ +150	°C	

■ ELECTRICAL CHARACTERISTICS

PARAMETER	SYMBOL	TEST CONDITIONS	MIN	TYP	MAX	UNIT
Off characteristics						
Drain-Source Breakdown Voltage	BV_{DSS}	$V_{GS}=0V, I_D=250\mu A$	20	-	-	V
Breakdown Voltage Temperature Coefficient	$\frac{\Delta BV_{DSS}}{\Delta T_J}$	$I_D=1mA$, Reference to 25°C	-	0.03	-	V/°C
Drain-Source Leakage Current	I_{DSS}	$V_{DS}=20V, V_{GS}=0V$,	-	-	1	μA
Gate-Source Leakage Current	I_{GSS}	$V_{GS}=\pm 8V$	-	-	± 100	nA
On characteristics						
Gate Threshold Voltage	$V_{GS(TH)}$	$V_{DS}=V_{GS}, I_D=250\mu A$	0.5	-	1.5	V
Drain-Source On-State Resistance	$R_{DS(ON)}$	$V_{GS}=4.5V, I_D=6.0A$	-	19	25	m Ω
		$V_{GS}=2.5V, I_D=5.2A$	-	23	32	m Ω
Dynamic characteristics						
Input Capacitance	C_{iss}	$V_{DS}=20V, V_{GS}=0V, f=1.0MHz$	-	370	-	pF
Output Capacitance	C_{oss}		-	78	-	pF
Reverse Transfer Capacitance	C_{rss}		-	73	-	pF
Switching characteristics						
Total Gate Charge	Q_G	$V_{DS}=20V, V_{GS}=4.5V, I_D=6.0A$	-	8.4	-	nC
Gate Source Charge	Q_{GS}		-	1	-	nC
Gate Drain Charge	Q_{GD}		-	1.8	-	nC
Turn-ON Delay Time	$t_{D(ON)}$	$V_{GS}=5V, V_{DS}=10V, R_D=10\Omega, R_G=6\Omega, I_D=6A$	-	3.6	-	ns
Turn-ON Rise Time	t_R		-	2.7	-	ns
Turn-OFF Delay Time	$t_{D(OFF)}$		-	19	-	ns
Turn-OFF Fall-Time	t_F		-	7.6	-	ns
Source-drain diode ratings and characteristics						
Drain-Source Diode Forward Voltage	V_{SD}	$I_S=1.7A, V_{GS}=0V$	-	-	1.2	V
Diode Continuous Forward Current	I_S	$V_D=V_G, V_S=1.3V$	-	-	6	A

Note: Pulse Test : Pulse width $\leq 300\mu s$, Duty cycle $\leq 2\%$.

■ TYPICAL CHARACTERISTICS

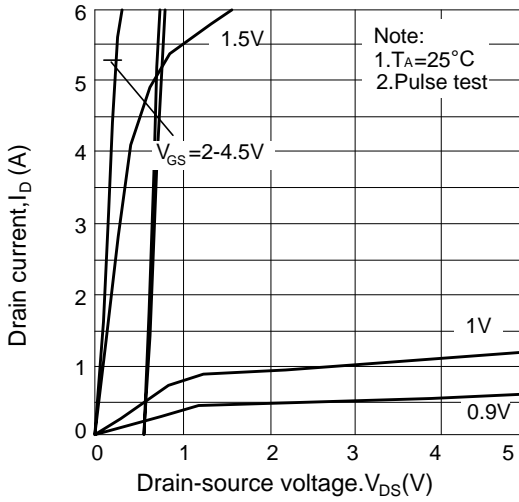

Figure 1: Drain current vs. drain-source voltage

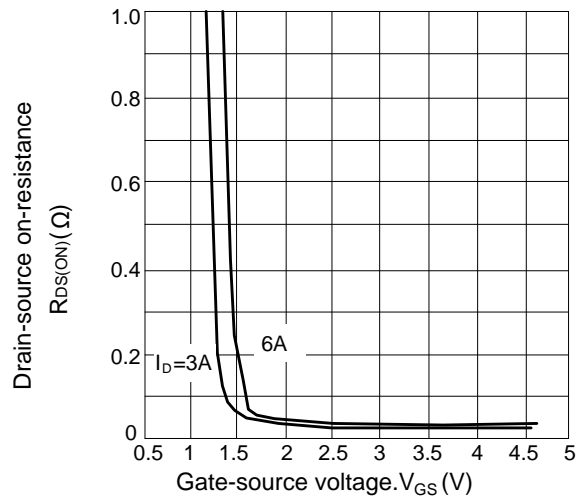

Figure 2: Drain-source on-resistance vs. gate

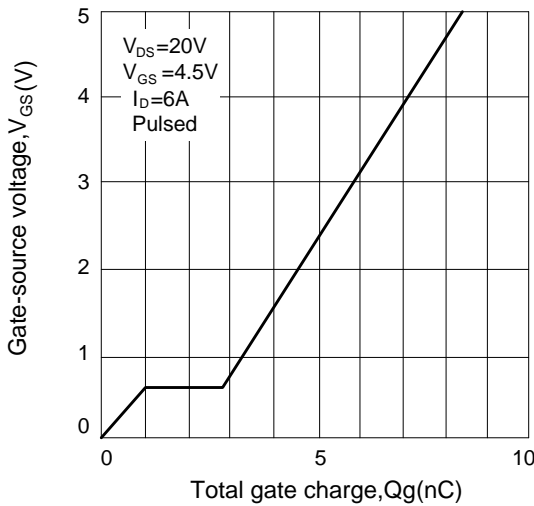

Figure 3: Gate charge characteristics

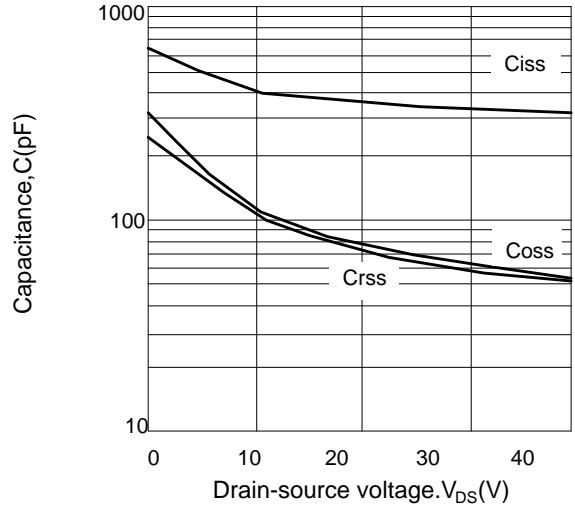

Figure 4: Capacitance characteristics

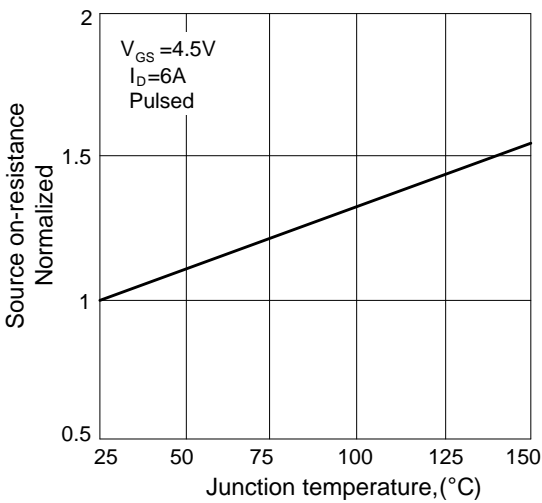

Figure 5: Drain-source on-resistance vs. junction temperature

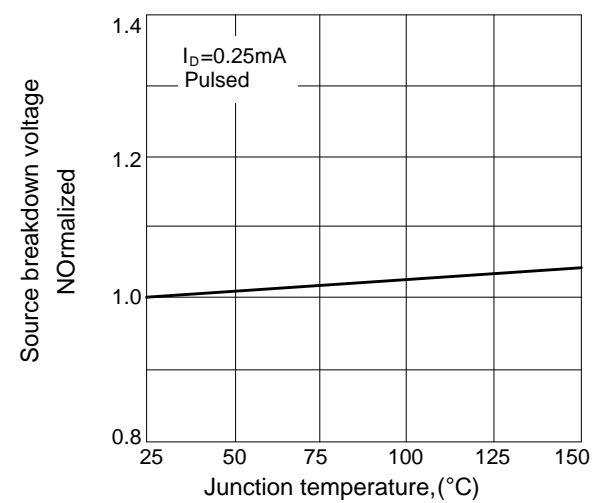

Figure 6: Breakdown voltage vs. junction temperature

■ TYPICAL CHARACTERISTICS(Cont.)

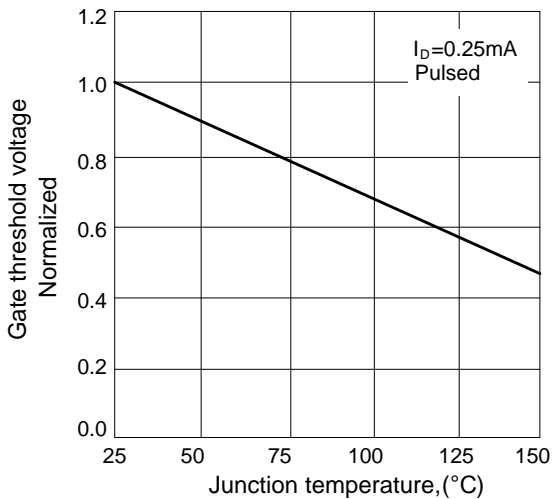

Figure 7: Gate threshold voltage vs. junction temperature

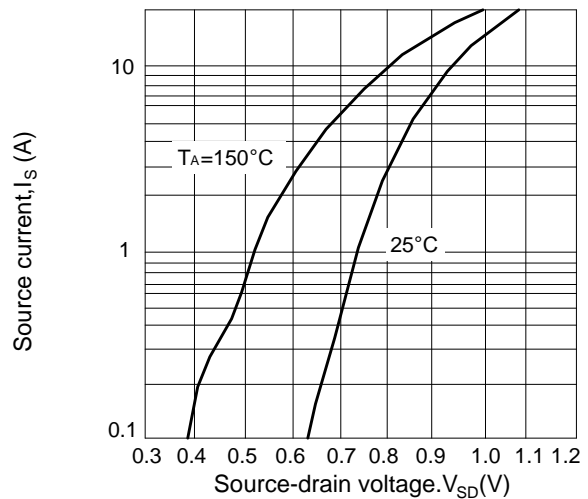

Figure 8: Source current vs. source-drain voltage

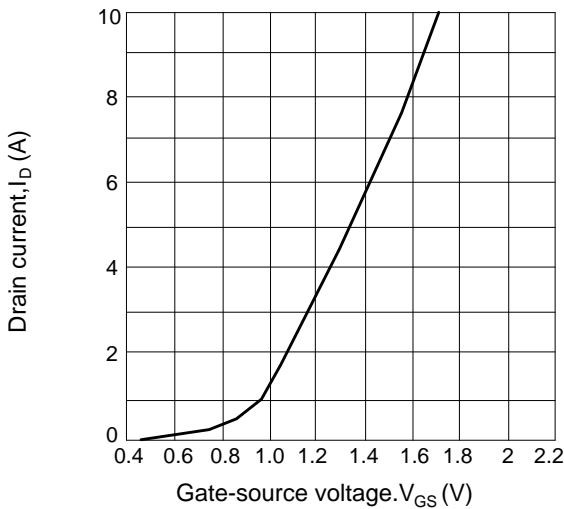

Figure 9: Drain current vs. case-source voltage

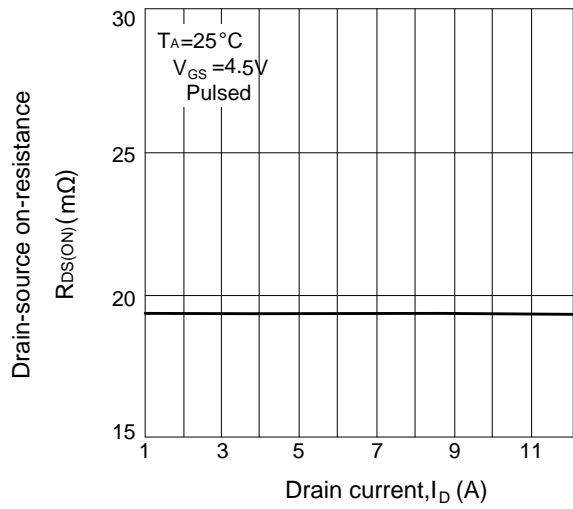

Figure 10: Drain-source on-resistance vs. drain current

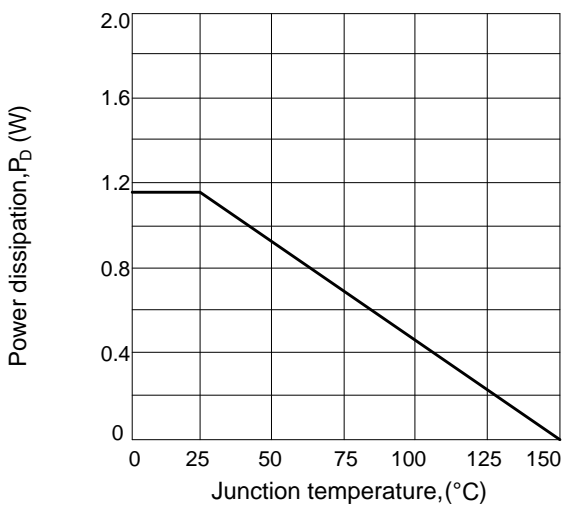

Figure 11: Power dissipation vs. junction temperature

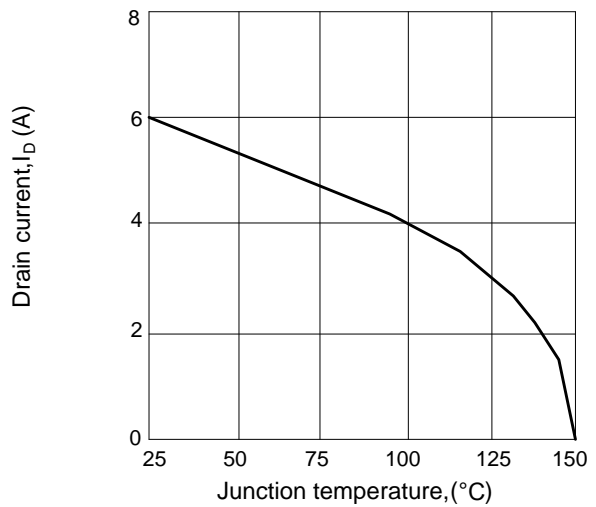
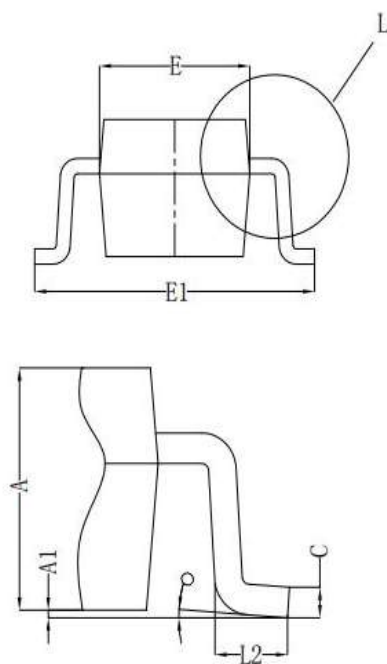
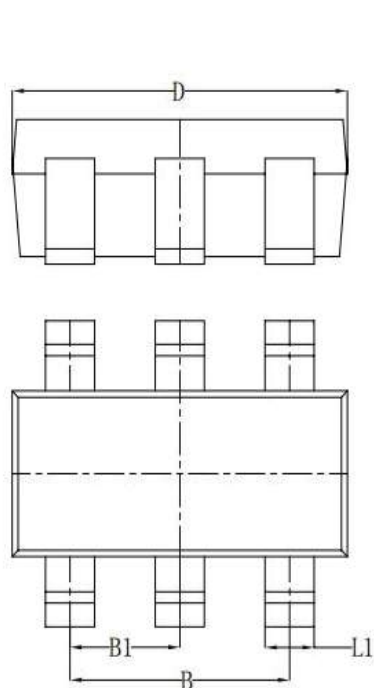

Figure 12: Drain current vs. junction temperature

■ SOT-23A-6L PACKAGE OUTLINE DIMENSIONS



Symbol	Dim in mm		
	Min	Nor	Max
A	1.050	1.100	1.150
A1	0.000	0.050	0.100
L1	0.300	0.400	0.500
C	0.100	0.150	0.200
D	2.820	2.920	3.020
E	1.500	1.600	1.700
E1	2.650	2.800	2.950
B	1.800	1.900	2.000
B1	0.950 TYP		
L2	0.300	0.450	0.600
o	0°	4°	8°