

<p>NPN型 小功率 贴片高压三极管 NPN High Voltage Transistor SMD</p>	<p>SS8050 对应其他工业型号</p>
<ul style="list-style-type: none"> ■ Transistor Polarity: NPN ■ Transistor pinout: BEC ■ SOT-23 Package ■ Marking Code: Y1 ■ hFE: 100~200, 200~300 ■ Ideal for Medium Power Amplification and Switching 	

<p style="text-align: center;">Inner circuit</p>  <p style="text-align: center;">SOT-23 内部结构</p>	<p style="text-align: center;">SS8050</p>  <p style="text-align: center;">SOT-23 管脚排列</p>	<p style="text-align: center;">元件标识 (打印)</p>  <p style="text-align: center;">DEVICE MARKING:</p>
--	--	---

■ CLASSIFICATION OF hFE

RANK	L	H
RANGE	100~200	200~300

MAXIMUM RATINGS

Parameter	Symbol	Value	Unit
Collector-Base Voltage	V_{CB0}	40	V
Collector-Emitter Voltage	V_{CE0}	25	V
Emitter-Base Voltage	V_{EB0}	6	V
Collector Current	I_c	1500	mA
Collector Power Dissipation	P_c	300	mW
Operation Junction and Storage Temperature Range	T_J, T_{stg}	-55~+150	°C

■ ELECTRICAL CHARACTERISTICS (T_A=25°C unless otherwise noted)

Parameter	Symbol	Test conditions	Min	Typ	Max	Unit
Collector-base breakdown voltage	$V_{(BR)CBO}$	$I_C=100\mu A, I_E=0$	40	-	-	V
Collector-emitter breakdown voltage	$V_{(BR)CEO}$	$I_C=0.1mA, I_B=0$	25	-	-	V
Emitter-base breakdown voltage	$V_{(BR)EBO}$	$I_E=100\mu A, I_C=0$	5	-	-	V
Collector cut-off current	I_{CBO}	$V_{CB}=40V, I_E=0$	-	-	0.1	μA
Collector cut-off current	I_{CEO}	$V_{CE}=20V, I_E=0$	-	-	0.1	μA
Emitter cut-off current	I_{EBO}	$V_{EB}=5V, I_C=0$	-	-	0.1	μA
DC current gain	$h_{FE(1)}$	$V_{CE}=1V, I_C=100mA$	120	-	400	-
	$h_{FE(2)}$	$V_{CE}=1V, I_C=800mA$	40	-	-	-
Collector-emitter saturation voltage	$V_{CE(sat)}$	$I_C=800mA, I_B=80mA$	-	-	0.5	V
Base-emitter saturation voltage	$V_{BE(sat)}$	$I_C=800mA, I_B=80mA$	-	-	1.2	V
Transition frequency	f_T	$V_{CE}=10V, I_C=50mA$ $f=30MHz$	100	-	-	MHz

■ TYPICAL CHARACTERISTICS (Cont.)

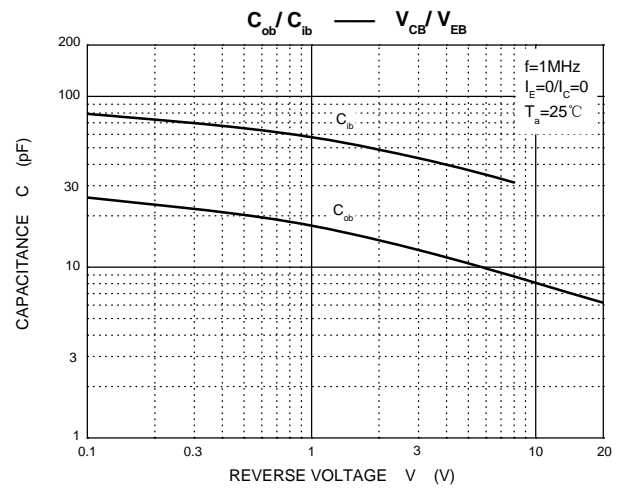
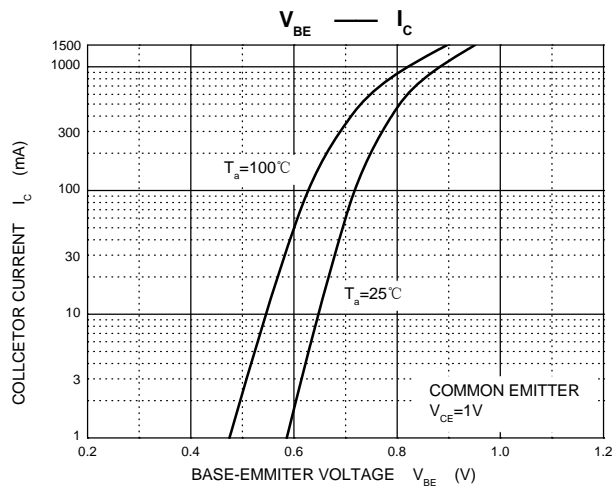
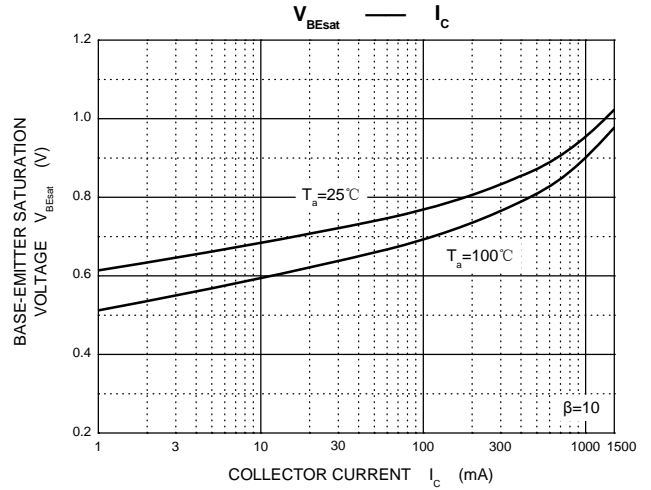
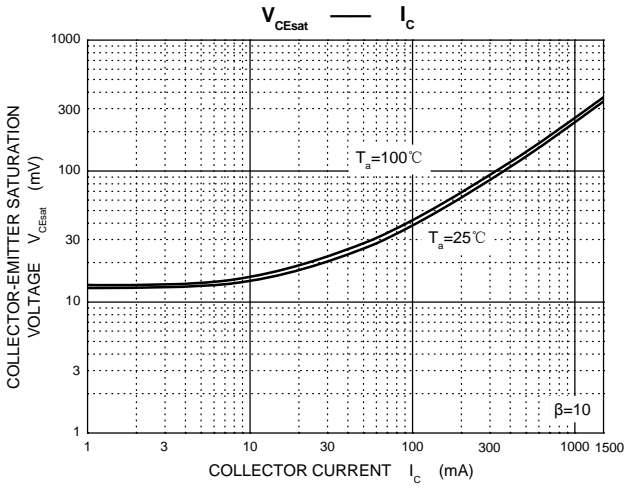
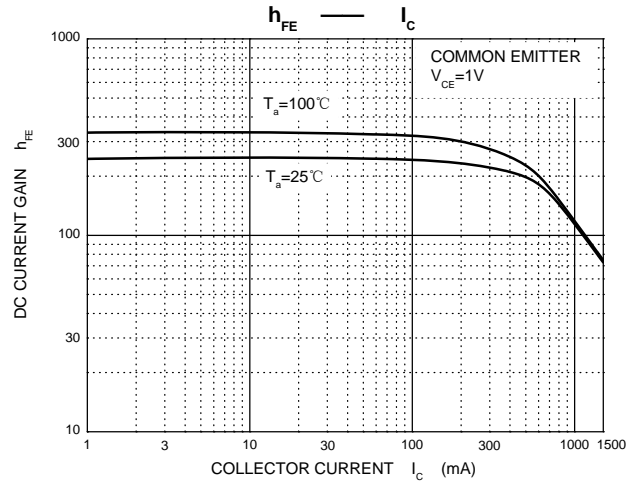
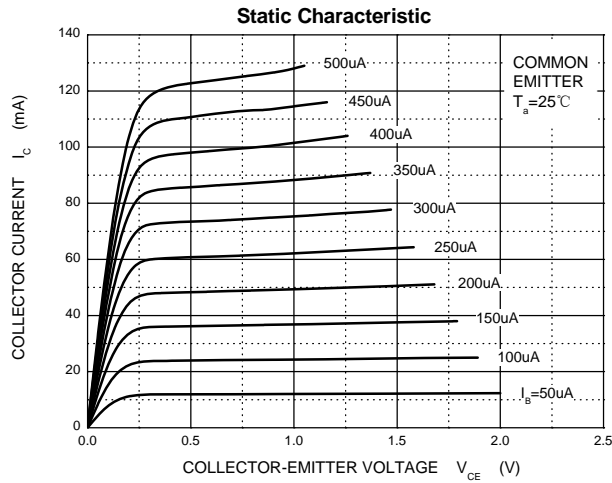

■ TYPICAL CHARACTERISTICS

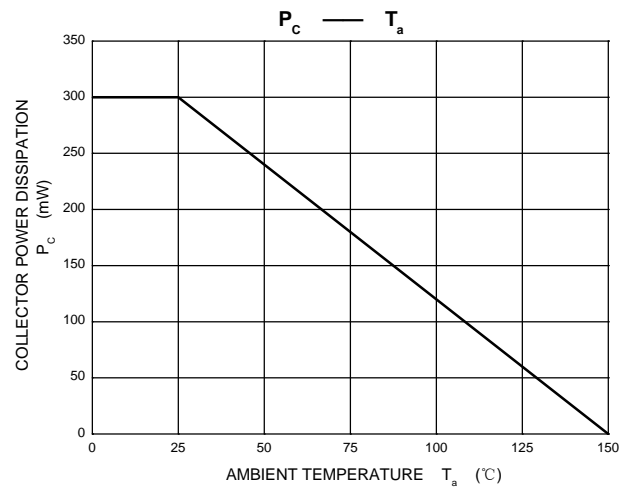
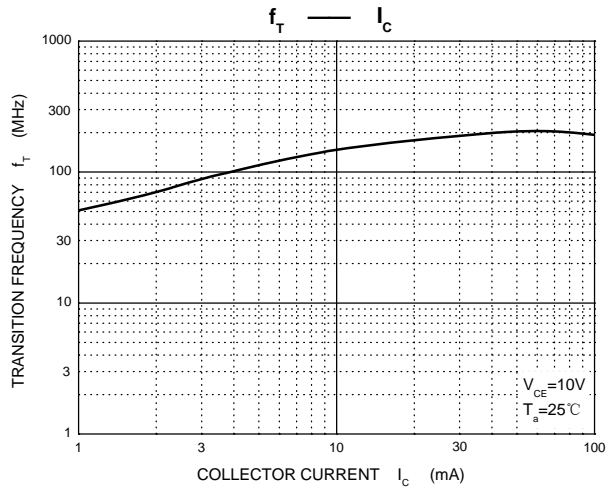

■ DIMENSION

单位 (UNIT) : mm

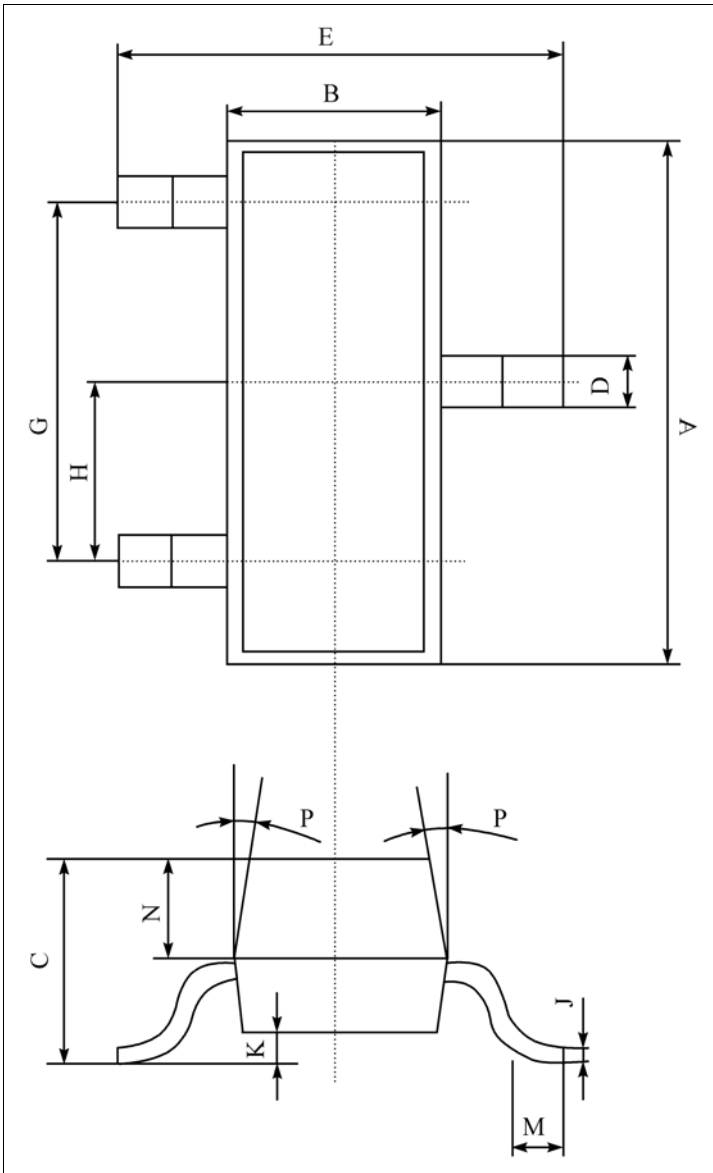

序号	数值及公差
A	2.90±0.10
B	1.30±0.10
C	1.00±0.10
D	0.40±0.10
E	2.40±0.20
G	1.90±0.10
H	0.95±0.05
J	0.13±0.05
K	0.00-0.10
M	≥0.20
N	0.60±0.10
P	7±2°

Packing
SOT-23 包装规格
SMD片式表面贴封装
包装方式: 载带卷盘包装
Tape & Reel, 3Kpcs/Reel
每卷数量3000只 (3Kpcs/Reel)
每盒数量45000只 (45Kpcs/BOX)
每箱数量180000只 (180Kpcs/Cartons)

SOT-23 Tape and reel

SOT-23 Embossed Carrier Tape

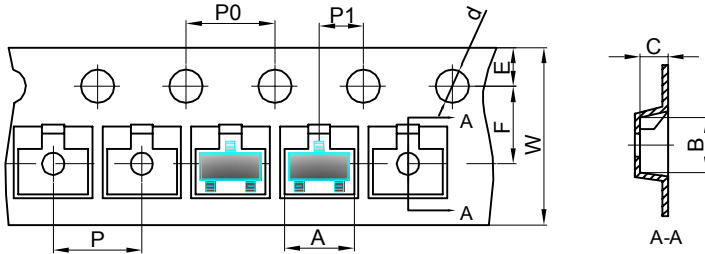

Dimensions are in millimeter										
Pkg type	A	B	C	d	E	F	P0	P	P1	W
SOT-23	3.15	2.77	1.22	Ø1.50	1.75	3.50	4.00	4.00	2.00	8.00

SOT-23 Tape Leader and Trailer

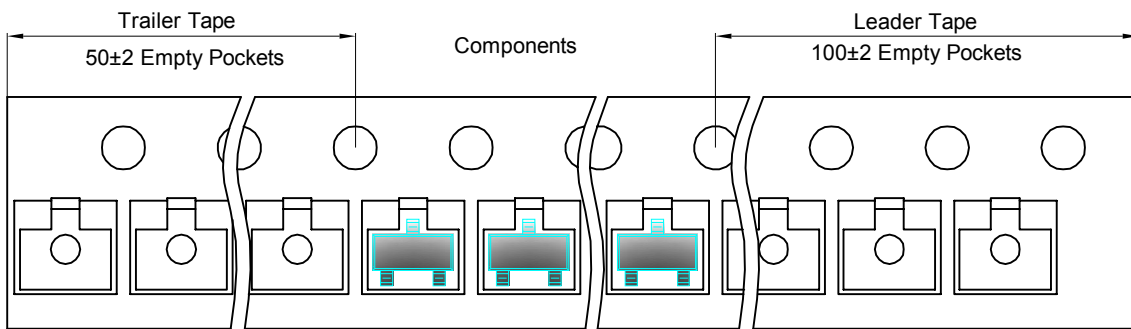

SOT-23 Reel

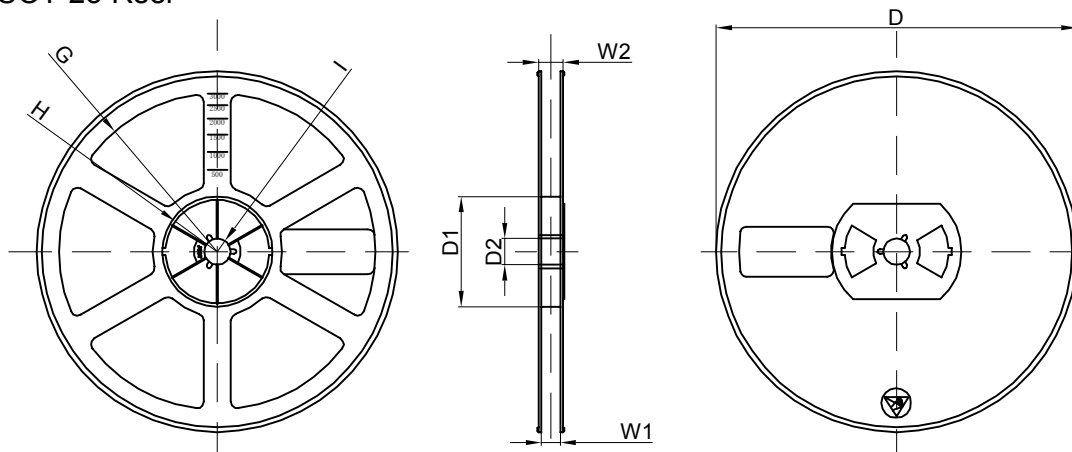

Dimensions are in millimeter								
Reel Option	D	D1	D2	G	H	I	W1	W2
7" Dia	Ø178.00	54.40	13.00	R78.00	R25.60	R6.50	9.50	12.30

REEL	Reel Size	Box	Box Size(mm)	Carton	Carton Size(mm)	G.W.(kg)
3000 pcs	7 inch	45,000 pcs	192×192×193	180,000 pcs	404×404×214	